

BEFORE YOU INSTALL PRAXIS WORKS M30 BB86 / BB92 YOU MUST CHECK YOUR FRAME!

BB86 / BB92 FRAME GAUGE

GO / NO-GO - Using only *FINGER PRESSURE*, the frame gauge must slide into the BB86/92 frame bore completely for it to be a **GO** and ok for installation of the Praxis M30 BB86/92 bottom bracket.



DO NOT FORCE THE GAUGE

If the gauge only fits one side of frame, or it only slides in partially, then the frame is a **NO-GO** for installation. **Do not force the gauge into the frame.** Example - Do not forcefully push/hit with heel of hand, do not hammer or use a blunt object to strike the gauge into a frame.





M30 BB86_{ROAD} / BB92_{MTN}



SAFETY INFORMATION - READ BEFORE RIDE

Since specific tools and experience are necessary for proper installation, it is recommended that the product be installed by a qualified bicycle technician.

Read the service instructions of your crank carefully prior to installing the parts. Loose, worn or damaged parts may cause riding problems and serious injury may occur as a result. If installation and adjustments are not carried out correctly, the chain may come off and this may cause you to fall off the bicycle which could result in serious injury. **Read these instructions carefully, and keep them for later use.**

- Ensure that the BB86 / BB92 frame shell is clean and not damaged **before instal.**
- Before riding the bicycle, check that there is no play or looseness in the bottom bracket connection. Also, be sure to retighten the crank arms and pedals at periodic intervals.
- If you feel any looseness or 'play' in the bearings, the bottom bracket should be inspected/replaced.
- Be sure to read the instructions for your front chainrings/crank in conjunction with these service instructions.
- **Do not wash the bottom bracket with high-pressure jets of water.**
- For maximum performance it is required to remove and periodically inspect/clean your Praxis Works bottom bracket.
- Parts are not guaranteed against natural wear or deterioration resulting from normal use.
- For any questions regarding methods of installation, adjustment, maintenance or operation, please contact a professional bicycle dealer or call Praxis Works.
- Praxis Works assumes no responsibility for damages or injury related to improperly installed components.
- **READ THE STEP BY STEP INSTRUCTIONS PROVIDED ON THE OTHER SIDE.**

WARRANTY

- Praxis Works Bottom Bracket products are warranted to be free from defects in materials or workmanship for two years after original purchase. The warranty is non-transferable and valid to the original purchaser of the product only.
- Any attempt to modify the product in any way such as drilling, grinding or painting will void the warranty.
- This warranty is not valid for "abused" or neglected products, or products that are damaged by improper installation.
- If a defect is found, our entire liability and your sole remedy shall be, at our option, free repair or replacement of the Praxis product.
- Except as expressly required by law, Praxis Works shall not be held liable for any indirect, special, or consequential damages.

THIS WRITTEN EXPRESS WARRANTY IS IN LIEU OF ALL OTHER WARRANTIES, IMPLIED OR EXPRESSED. This warranty gives you specific legal rights, and you may also have other rights which vary state to state. **For more information on warranty policy and instructions for completing a warranty claim, check out the Full Warranty Policy found at our website. www.praxis-works.com**

M30 BB Compatibility & Spec	
CRANKSET	Compatible with Praxis M30 Based cranks. BB86 ROAD cranks only - BB92 for MTB cranks only.
FRAME SHELL	BB86 ROAD FRAMES BB92 MTB FRAMES - 41mm Diameter Frame Shell
FRONT DERAILLEUR	Braze On, ST clamp

NEEDED TOOLS:

A professional grade bearing/cup press tool to install the two bearings. Park Tool #BBT-30.3 Bearing Remover. Loctite 609 retaining compound for metal shell frames of Loctite Superflex Clear RTV Silicone Adhesive for carbon shell frames.

PART INCLUDED:

- 1 RH/Drive Wave Washer (ID=30mm)
- 1 RH/Drive Cover (ID=30mm)
- 1 RH/Drive M30 Bearing (ID=30mm)
- 1 LH/Non-Drive M30 Bearing (ID=28mm)
- 1 LH/Non Drive Black AL Cover (ID=28mm)

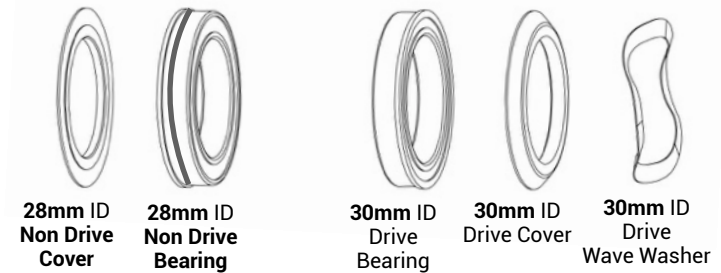

FRAME MEASUREMENT

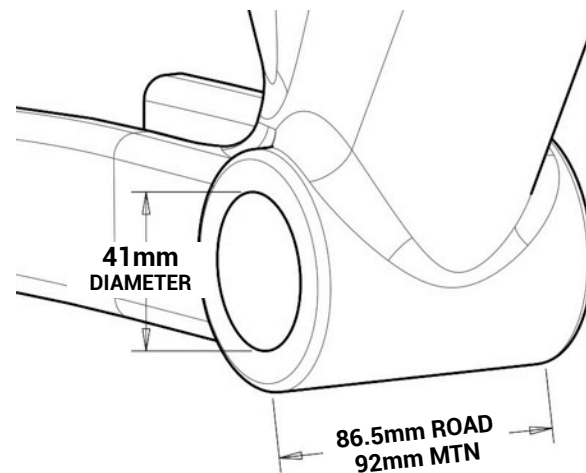

NOTE- This groove marking is a visual ref for the 28mm ID Bearing



1. YOU MUST PREPARE - FRAME/BEARING

METAL SHELL SURFACE

Clean frame shell - Then you must use "Loctite 609" retaining compound to prep the frame & bearing press surface for install. Spread a thin coat around the metal shell PF surface, and on the outer bearing surface.



CARBON SHELL SURFACE

Clean frame shell - Then you must use "Loctite Superflex" Clear RTV Silicone Adhesive to prep the frame & bearing press surface for install. Spread a thin coat around the carbon shell PF surface, and on the outer bearing surface. This is a Room Temperature Vulcanizing silicone sealant. **Once pressed, it must cure for *24hrs before riding.***

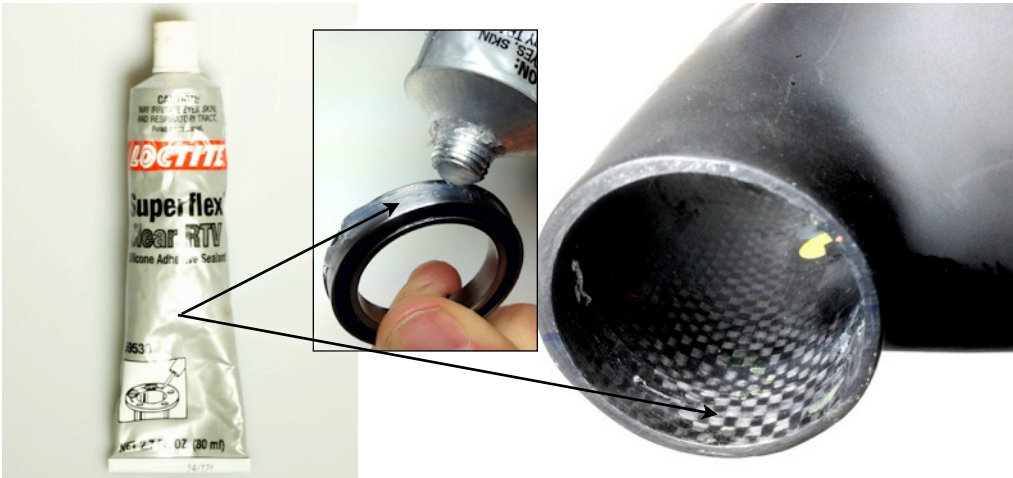

2. One side at a time, with professional press tool, carefully press M30 BB86 bearings into frame shell. The frame and bearing surfaces MUST BE PREPARED with a small amount of the required adhesive we show. See Step 1.

REMEMBER- 30MM ID bearing is the Drive side, 28MM ID bearing is the Non-Drive side.

Press each bearing till the lip edge of the bearing is completely flush with the frame shell edge. There can be no visual gap.

3. After both bearings are pressed, install the M30 spindle crank. Slide the 30mm ID wavy washer down onto spindle, and then slide on the 30mm ID cover with the logo facing away from frame. Put some grease on the spindle and splines as shown, and push the crank all the way through both bearings.

4. Place 28mm cover over the Non-Drive bearing with logo facing away frame. Then thread on Non-Drive crank arm with 8mm Hex. With a torque wrench, tighten the main crank bolt to 48-55 newton meters of torque. Installation finished.

BEFORE RIDING, fully tune front derailleur.

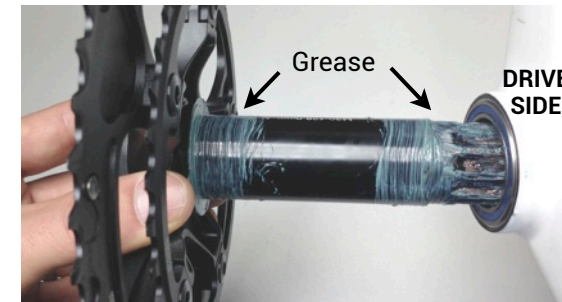
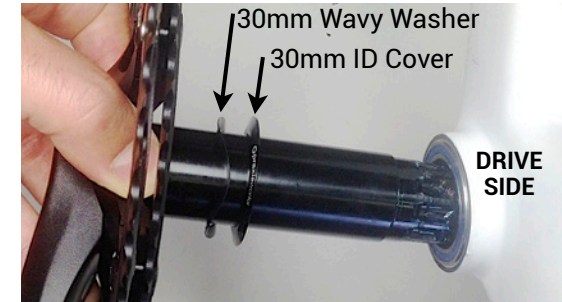
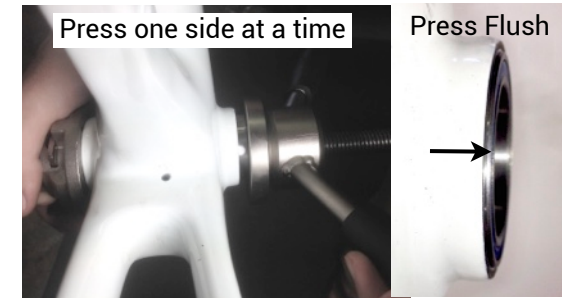

REMOVAL - Using the Park Tool #670.2 bearing remover and a rubber mallet gently knock each bearing out from the inside outward. Remove the Non-Drive bearing first, then remove Drive the bearing.

