

DISC BRAKE HYDRAULIC SYSTEM

WARNING!

This technical manual is intended for use by professional mechanics.

Anyone who is not professionally qualified to assemble bicycles should not attempt to install and operate on the components because of the risk of carrying out incorrect operations that could cause the components to malfunction with the consequent risk of accidents, physical injury or even death.

Info for professional mechanics: Although the User Manual that comes with the product is intended mainly for the end user, it is vital that professional mechanics also read and understand it so that they are adequately prepared to explain the product to customers, making certain that all care is taken to ensure its safe and proper use.

The actual product may differ from what is illustrated, as the specific purpose of these instructions is to explain the procedures for installing and adjusting the component.

1 - SAFETY RECOMMENDATIONS

WARNING!

Always wear protective gloves and glasses while working on the bicycle.

WARNING!

With Campagnolo brakes® braking is different and more powerful compared to standard braking systems. Improper use of this braking system could result in loss of control of the bicycle, accidents, physical injury or even death.

Please read and comply with all warnings and instructions.

Because each bicycle may handle differently, ensure that you are familiar with the braking technique (including brake lever pressure to be exerted and the controls) and functions of the particular bicycle in question. We advise you to use the recommended riding and braking techniques, where possible in a safe, unobstructed area, at least until you have familiarised yourself with the new braking system.

- If you apply excessive pressure to the front and/or rear brake, the wheel may lock and the bicycle may suddenly fall forward, putting you at risk of serious injury.

- Never touch the disc brake rotor, even when the bicycle is stationary. The rotor itself may be very hot, and could cause serious burns. You are also reminded to take great care when the bicycle is moving, as the rotor is sharp and could cause serious injury to the fingers if inserted into the rotor openings while in motion (Fig.1).

- If any of the following conditions occur, stop using the bicycle immediately:

- Any cracks or damage are visible on the rotor, even if these are minimal
- The rotor is worn beyond the prescribed limits
- The brake system is leaking fluid

Failure to observe the above indications could lead to accidents, physical injury or even death.

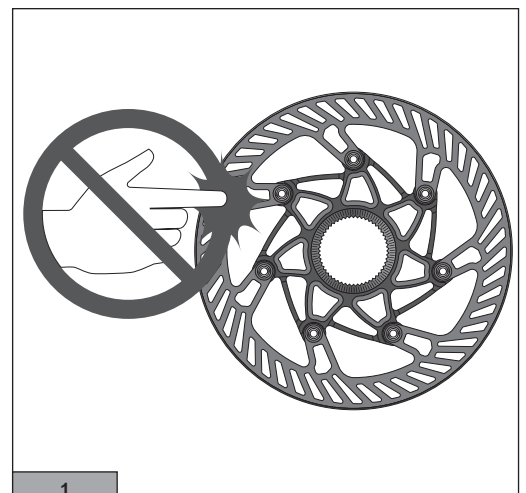

- If leaked oil comes into contact with the eyes, it may cause irritation: rinse with water and seek immediate medical attention.
- If leaked oil comes into contact with the skin, it may cause irritation: wash thoroughly using soap and water.
- Inhalation or ingestion of mineral oil vapours may cause nausea. Cover your nose and mouth and immediately go to a well-ventilated area. If necessary, seek professional medical attention.
- Never make any modifications to any Campagnolo® product.
- Any bent or damaged parts following impact or accidents must be replaced with original Campagnolo® parts.
- Wear close fitting and highly visible clothing (fluorescent colours or light colours).
- Avoid cycling at night because it is difficult for others to see you and obstacles on the road are difficult to distinguish. If using the bicycle at night, ensure that it is fitted with suitable lights and reflectors.
- Never use a bicycle or component with which you are not completely familiar or the use and maintenance operations of which are unknown. Second hand parts may have been used incorrectly or may be ruined, therefore they could break unexpectedly, causing an accident.
- If the bicycle is used in the wet remember that the braking power and tyre grip decrease significantly, making it more difficult to control. Therefore pay closer attention when riding on wet surfaces in order to prevent possible accidents.
- Always wear a correctly-fastened protective helmet and ensure that this is ANSI or SNELL approved.



WARNING!

Only original discs, pads and oil that are supplied with the Campagnolo drivetrain or original replacement parts must be used; failure to respect the above requirements could result in accidents, physical injuries or even death.

1.1 - BEFORE USING THE BICYCLE

DO NOT USE YOUR BICYCLE IF IT DOES NOT PASS THIS TEST – CORRECT ANY FAULTY SITUATIONS BEFORE USING THE BICYCLE.

- Make sure that all of the bicycle components, including (but not exclusively) brakes, pedals, handgrips, handlebars, frame and seat unit are in perfect condition and ready for use.
- Make sure that none of the bicycle components are bent, damaged or out of alignment.
- Check to ensure that all of the locking and fixing devices on the bicycle are properly adjusted. Bounce the bicycle on the ground to check whether you can see or hear any loose parts.
- Check all reflectors are securely mounted and are clean.
- Make sure the wheels are perfectly centred. Spin the wheel to ensure that it does not wobble up and down or from side to side.
- Spin the wheel to check that it rotates freely and to ensure that the brake pads are not touching the rotor when the brake levers are not depressed.
- Before using the bicycle, always check that the front and rear brakes are working correctly by testing the brake levers several times, ensuring that the front and rear rotors engage correctly.

2 - TECHNICAL SPECIFICATIONS

Ergopower Ultra-Shift /Power-Shift mechanical commands with adjustable free stroke (AMS) and brake lever position.

	11s	SHEATHS REAR DERAILLEUR	CABLE REAR DERAILLEUR	HOSE (EXTERNAL DIAMETER)
ERGOPOWER ULTRA-SHIFT	3 UP 5 DOWN	Ø 4.1 mm Campagnolo ultra-low friction	Ø 1.2 mm	5 mm
ERGOPOWER POWER-SHIFT (POTENZA 11™)	3 UP 1 DOWN	Ø 4.1 mm Campagnolo ultra-low friction	Ø 1.2 mm	5 mm

Ergopower EPS commands with connector for Super Record EPS and Record EPS drivetrain units and adjustable free stroke (AMS) and brake lever position.

	11s	SHEATHS REAR DERAILLEUR	CABLE REAR DERAILLEUR	HOSE (EXTERNAL DIAMETER)
ERGOPOWER EPS	10 UP 10 DOWN	Ø 4.1 mm Campagnolo ultra-low friction	Ø 1.2 mm	5 mm

OIL	CAMPAGNOLO MINERAL OIL (LB-200 / LB-200B / LB-200S)		
CALLIPERS	TYPE: DUAL-PISTON FLAT MOUNT Ø 22 mm		
PADS	CAMPAGNOLO ORGANIC PADS WITH WEAR INDICATORS		
DISCS	FRONT (mm)	160	
	REAR (mm)	140 or 160	
		160	

WARNING!

Only original discs, pads and oil that are supplied with the Campagnolo drivetrain or original replacement parts must be used; failure to respect the above requirements could result in accidents, physical injuries or even death.

2.1 - DISC SELECTION

This braking system cannot be used by cyclists who weigh more than 109 kg (240 lbs), or where the overall weight of the cyclist, the bike and any bags or accessories installed exceeds a total weight of 120 kg (265 lbs).

Only use original 160 mm discs on the front.

On the rear, use 140 mm or 160 mm discs in accordance with your weight and the overall weight of the bicycle, bags/panniers or other accessories installed and yourself.

When selecting the disc, the weight limits must be respected (your weight and the total weight):

REAR DISC (mm)	CYCLIST WEIGHT (KG/LBS)	OVERALL WEIGHT: CYCLIST + BIKE + ACCESSORIES (KG/LBS)
140 or 160	up to 82/180	up to 90/198
160	up to 109/240	up to 120/265

WARNING!

Failure to respect the abovementioned weight limits could result in loss of control of the bicycle, accidents, physical injury or even death.

WARNING!

Failure to respect the above-mentioned weight limits will void the product warranty.

WARNING!

When using a 160 mm disc at the rear, please remember that braking power will be increased, and accordingly, may result in an increased risk of rear wheel locking.
Practice braking in a safe place until you are familiar with the braking power obtained with a rear disc of different sizes.

WARNING!

Campagnolo S.r.l. does not authorise the modification of the disc through the use of adapters for converting the AFS/6 screw disc locking system.

The use of adapters for converting the AFS/6 screw disc locking system, could result in loss of control of the bicycle, accidents, physical injury or even death.

WARNING!

The use of adapters for converting AFS/6 screws, will void the product warranty.

3 - COMPATIBILITY

IMPORTANT! COMPATIBILITY NOTICE

The use of any components not considered to be compatible by Campagnolo could significantly reduce the drivetrain's overall performance.

ERGOPOWER	CRANKSET	CHAINRINGS	REAR DERAILLEUR	FRONT DERAILLEUR
POWER-SHIFT (POTENZA 11™)	ULTRA-TORQUE (POTENZA 11™) HO	MARKED CD	POTENZA 11™ HO	POTENZA 11™
ULTRA-SHIFT H11	ULTRA-TORQUE H11	MARKED H	MARKED HO	SUPER RECORD / RECORD 11s (2015)

EPS	ERGOPOWER	ULTRA-SHIFT 11s
	CRANKSET	ULTRA-TORQUE H11
	CHAINRINGS	MARKED H
	REAR DERAILLEUR	SUPER RECORD EPS* / RECORD EPS*
	FRONT DERAILLEUR	SUPER RECORD / RECORD 11s (2015)
	INTERFACE	V3 with firmware higher than version 0.1.14
	WIRELESS MODULE	V3 with firmware higher than version 1.5.1
	POWER UNIT	V3 with firmware higher than version 0.0.24

* In the case of frames with thru-axles, use a rear derailleur produced in 2017 or later - these are concave shaped, ensuring perfect clearance between the rear derailleur and the frame.

WARNING!

Combinations other than those provided for in the above table could cause the drivetrain to malfunction and potentially be the cause of accidents, physical injury or even death.

4 - INTERFACE WITH THE FRAME

4.1 - INTERFACE WITH HANDLEBAR FOR ERGOPOWER MECHANICAL / EPS COMMANDS

WARNING!

Combinations other than those provided in the above table could cause the drivetrain to malfunction and potentially be the cause of accidents, physical injury or even death.

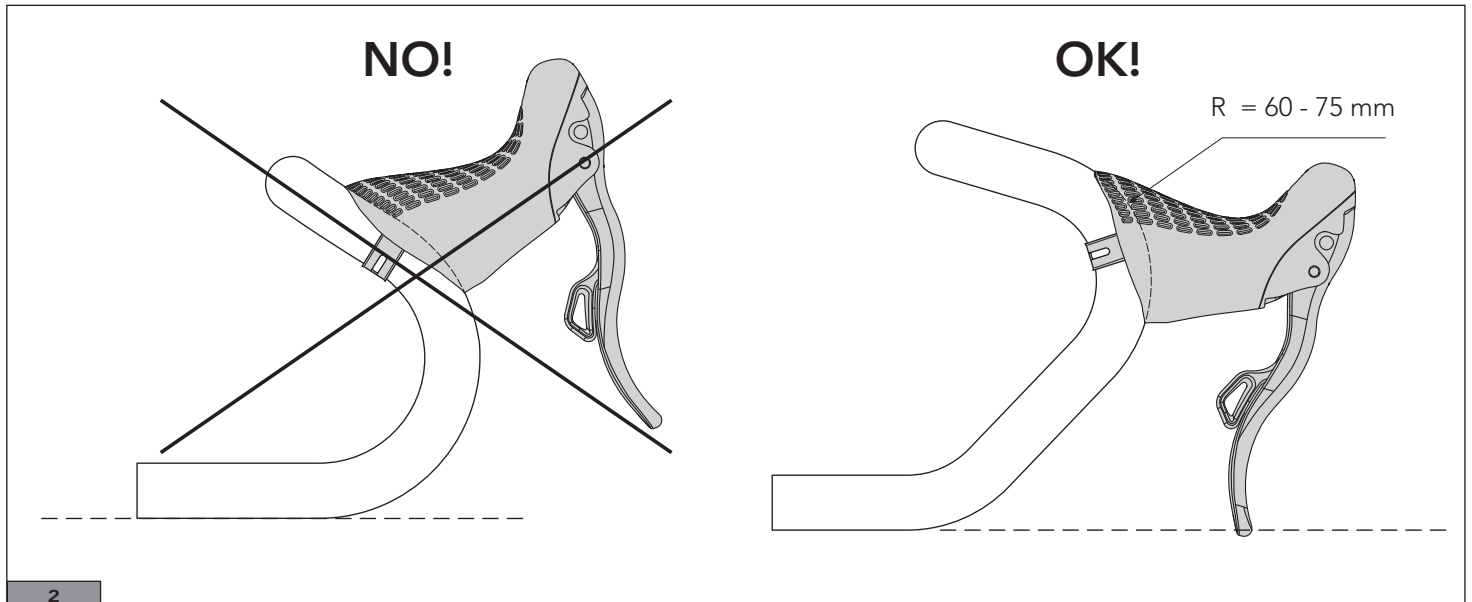
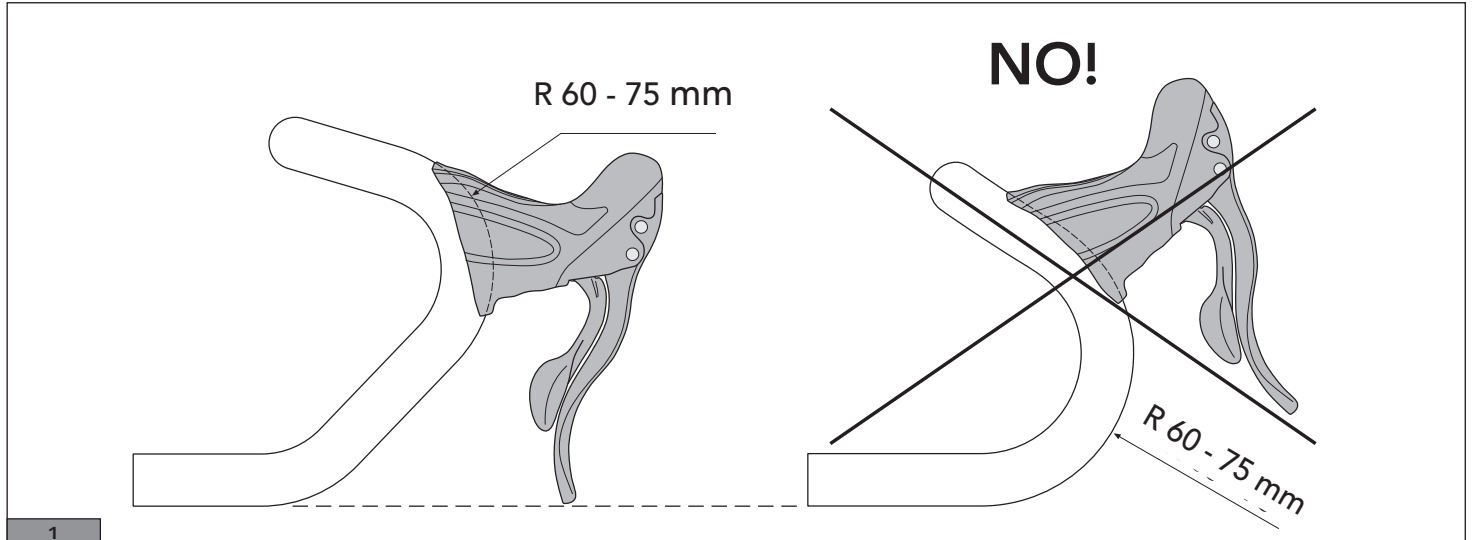

- Do not lodge the upper part of the command in the rectilinear section of the handlebar (Fig. 1 / Fig. 2).
- Lodge the command in the curved section measuring **R = 60 - 75 mm with a diameter = 23.8 - 24.2 mm** (including any ovalization) to guarantee more effective fastening (Fig. 1/ Fig. 2).

CAUTION

Make sure that the curved section of the handlebar where the command is to be fixed, has a sufficiently rough surface to ensure a better grip.

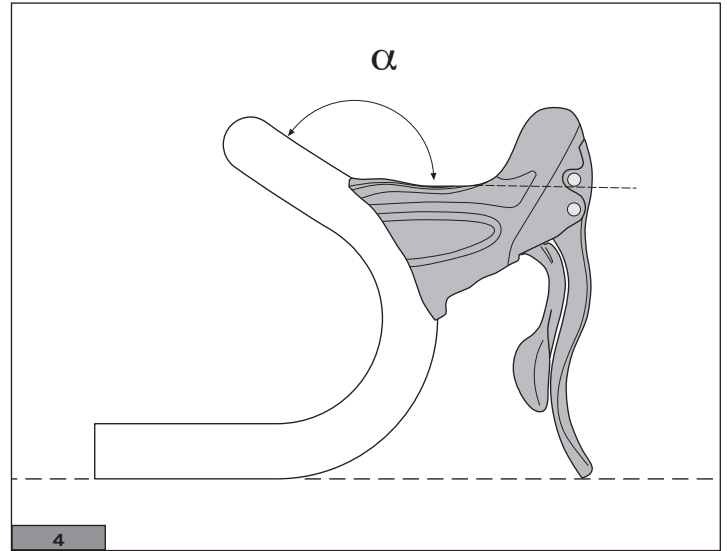
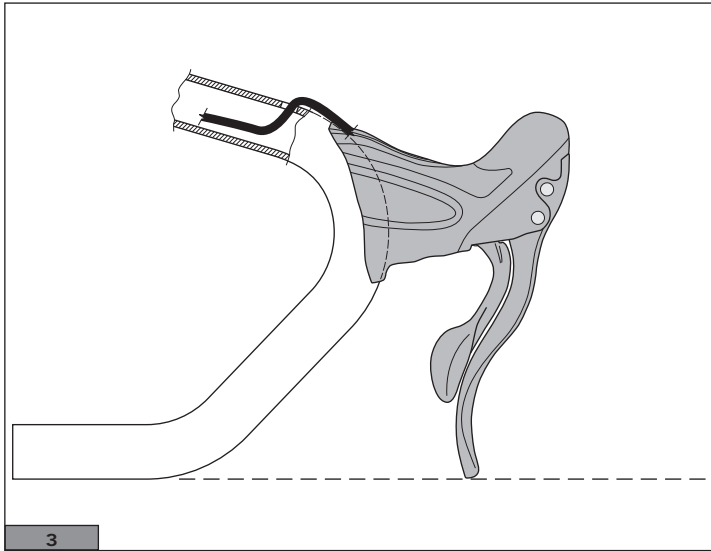

CAUTION

The cable routing illustrated in Figure 3 seriously compromises the drivetrain's gear shift and derailing performance.

DO NOT USE HANDLEBAR BENDS WITH THIS KIND OF ROUTING.

- Make sure that angle α is sufficiently wide to ensure that the housing is mounted correctly and the cable runs through it easily (Fig. 4).

4.2 - MINIMUM CHAINSTAY LENGTH

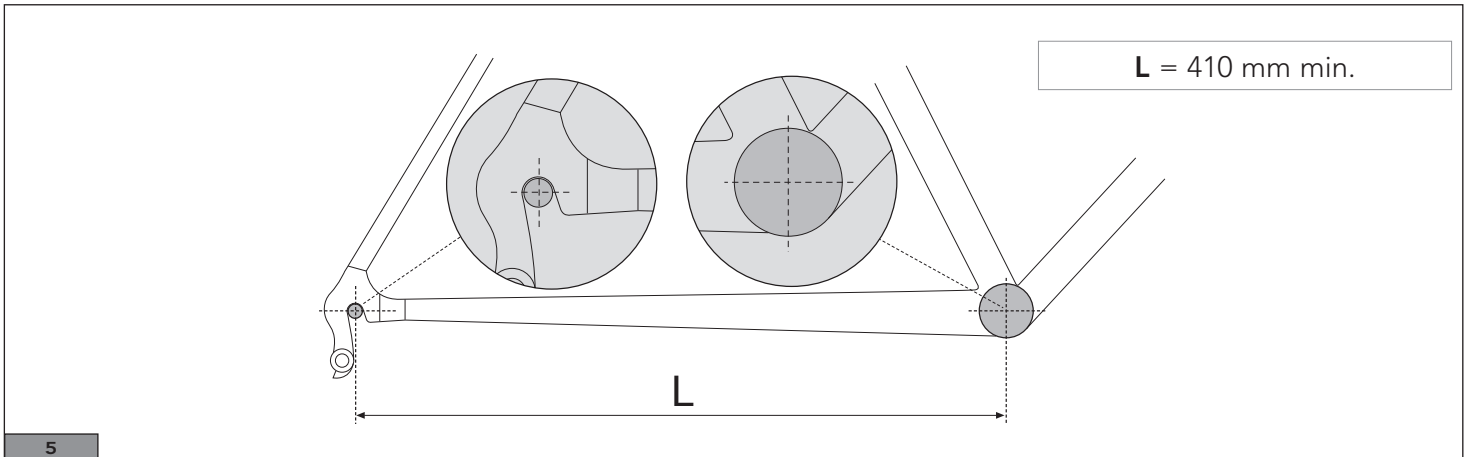

4.3 - INFORMATION ABOUT THE BEND RADIUS OF HYDRAULIC HOSES

IMPORTANT: The recommended minimum bend radius of the hose is 15 mm.

The presence of wrinkles on the outer hose wall does not indicate loss of functionality.

If there are evident signs of crushing or major dents on the outer surface of the hose, replace it, even if no loss of functionality has been identified.

4.4 - FORK SPECIFICATIONS FOR THE FRONT CALLIPER

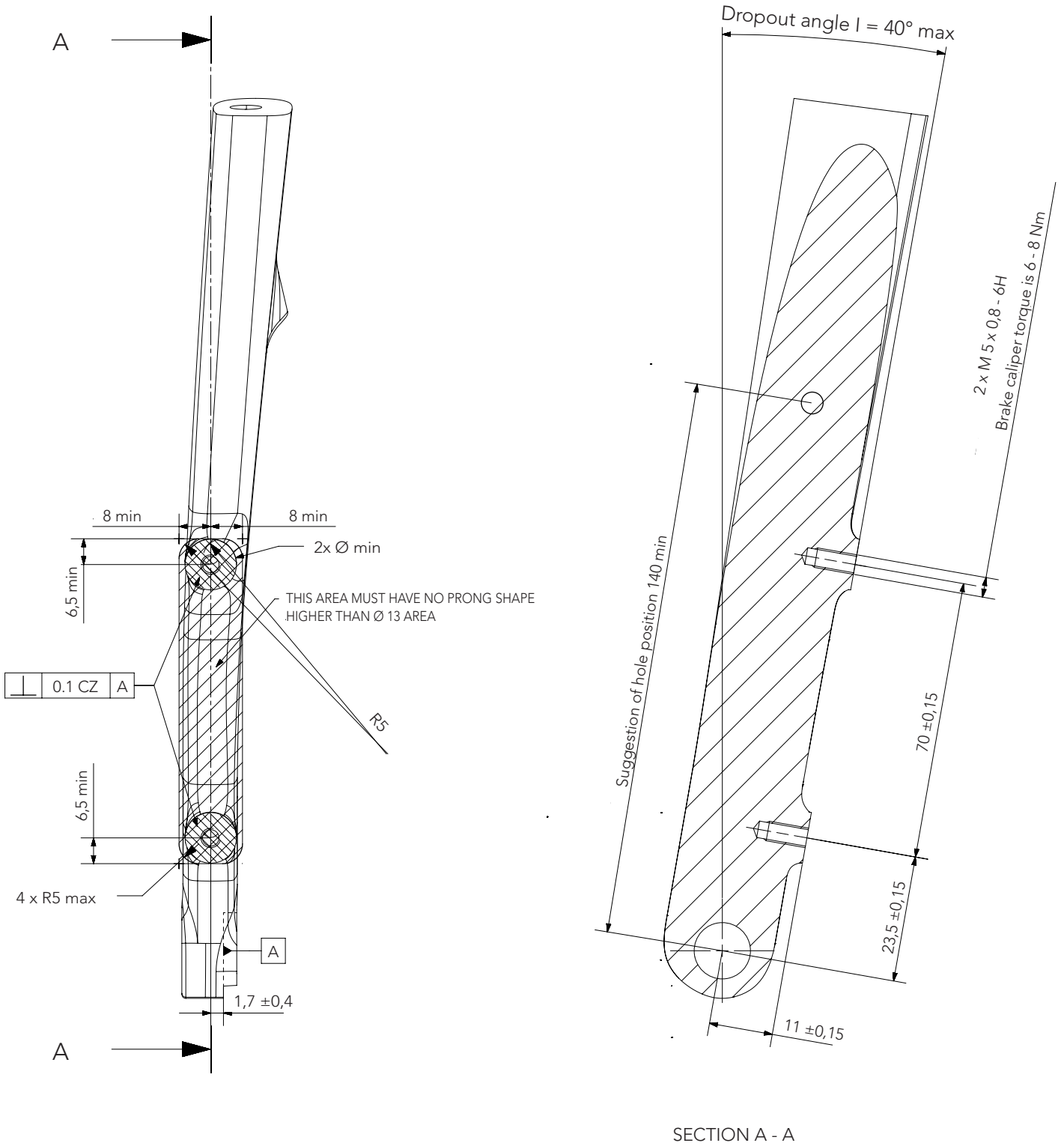

Note: measurements are expressed in mm

4.5 - LEFT-HAND CHAINSTAY FOR REAR CALLIPER

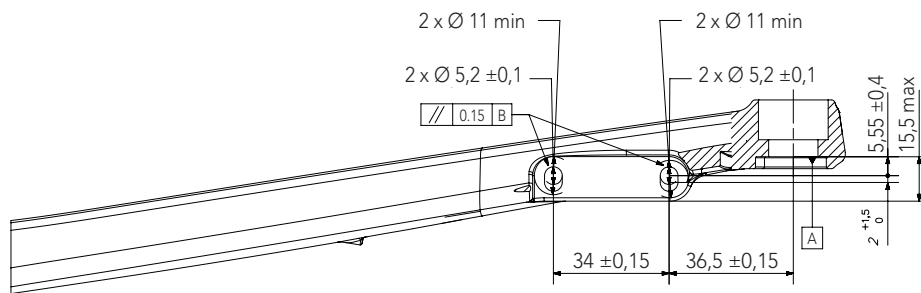
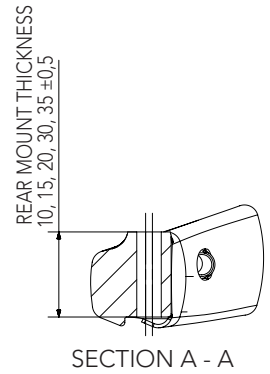
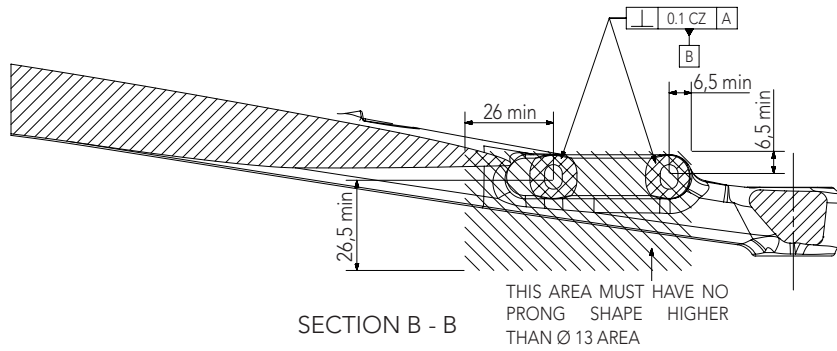
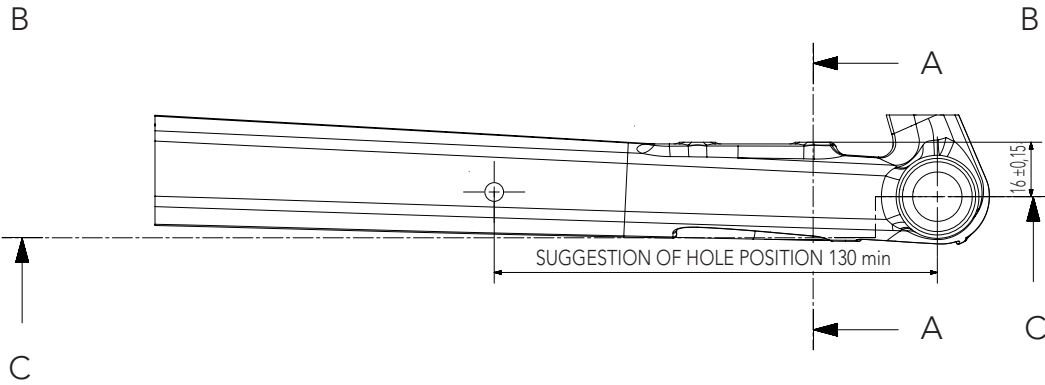

BRAKE CALIPER FIXING BOLT
CONTACT FACE IS Ø 11
BRAKE CALIPER FIXING BOLT
TIGHTENING TORQUE IS 6-8 Nm

Note: measurements are expressed in mm

5 - ASSEMBLY



WARNING!















Always wear protective gloves and glasses while working on the bicycle.



Please remember that all the assembly, disassembly, adjustment and maintenance procedures are described in the technical manual, which is available on our website www.campagnolo.com. Scan this QR code to access the home page directly.

5.1 - TOOLS FOR INSTALLING AND BLEEDING THE HYDRAULIC SYSTEM

Generic tools:

	ALLEN WRENCH		FLAT SCREWDRIVER
	ALLEN WRENCH		PHILLIPS SCREWDRIVER
	ALLEN WRENCH		FIXED WRENCH
	ALLEN WRENCH		TORX WRENCH T10
	ALLEN WRENCH		TORX WRENCH T20
	ALLEN WRENCH		TORX WRENCH T25
	ALLEN WRENCH		
	ALLEN WRENCH		

Note: Tools supplied by other manufacturers for components that are similar to Campagnolo® components may not be compatible with the Campagnolo® components. Similarly, tools supplied by Campagnolo S.r.l. may not be compatible with components from other manufacturers. Always check with your mechanic or with the tool manufacturer to ensure compatibility before using tools from one manufacturer on components from another manufacturer.

In addition to standard workshop tools, the following are also required:

→	Magura hydraulic hose cutter
→	Jagwire needle driver tool
→	Magura torque screwdriver with open bit adapter
→	Torque wrench - 4-20 Nm (with 8 mm bush and 5 mm hex bit)
→	Campagnolo Oil level tool UT-DB010 (for injecting the correct amount of oil into the system)
→	Campagnolo DB-100 bleeding tool (for filling and bleeding the system)
→	Campagnolo mineral oil (available in 100, 250 and 1000 ml containers, for filling the system)

! WARNING!

Campagnolo spare parts must only be installed by qualified mechanics with specialised skills, tools and adequate experience, following the installation instructions precisely. Installation by unqualified persons may cause malfunctions, accidents and serious or even fatal injury.

! DANGER!

Use Campagnolo LB-200 / LB-200S / LB-200B mineral oil only.

Using DOT oil or any other type other than Campagnolo oil, could damage the rubber seals irreparably. Failure to observe the above instructions could cause accidents, physical injury or even death.

5.2 - ASSEMBLING THE CAMPAGNOLO BLEED KIT

Fit the short tube with the M6 threaded connector onto the syringe with a hole.

Fit the long tube with the M4 threaded connector onto the syringe with no hole.



1

5.2 - PREPARING THE FRAME

- Remove all traces of paint from the areas where the callipers are to be installed on the fork and the left-hand chain stay. Also remove all traces of paint from the bottom part of the holes on the chain stay, where the rear calliper screw heads rest. (Fig.1 - 1.1).

5.2.1 - FRONT FORK

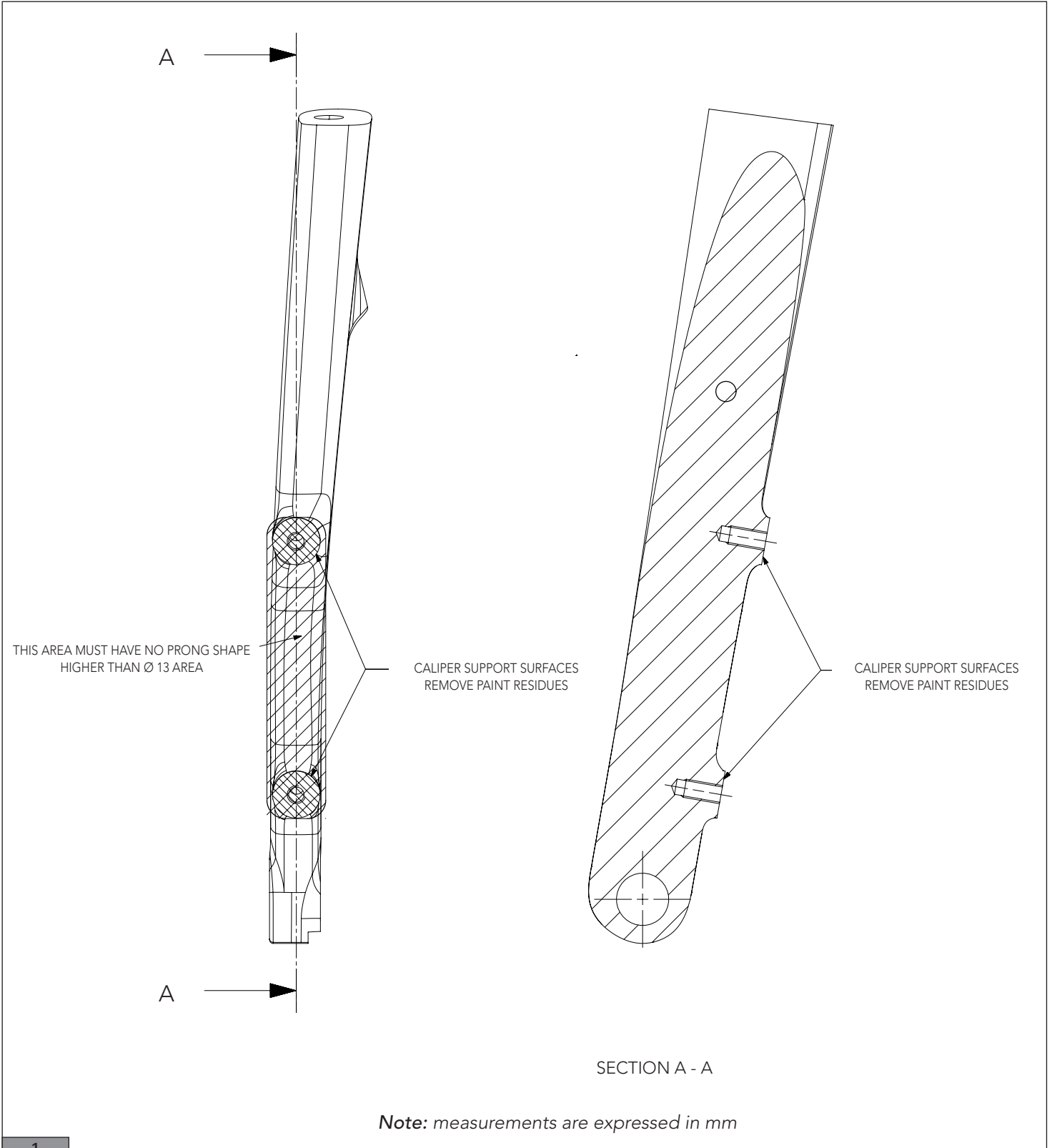

5.2.2 - REAR CHAINSTAY

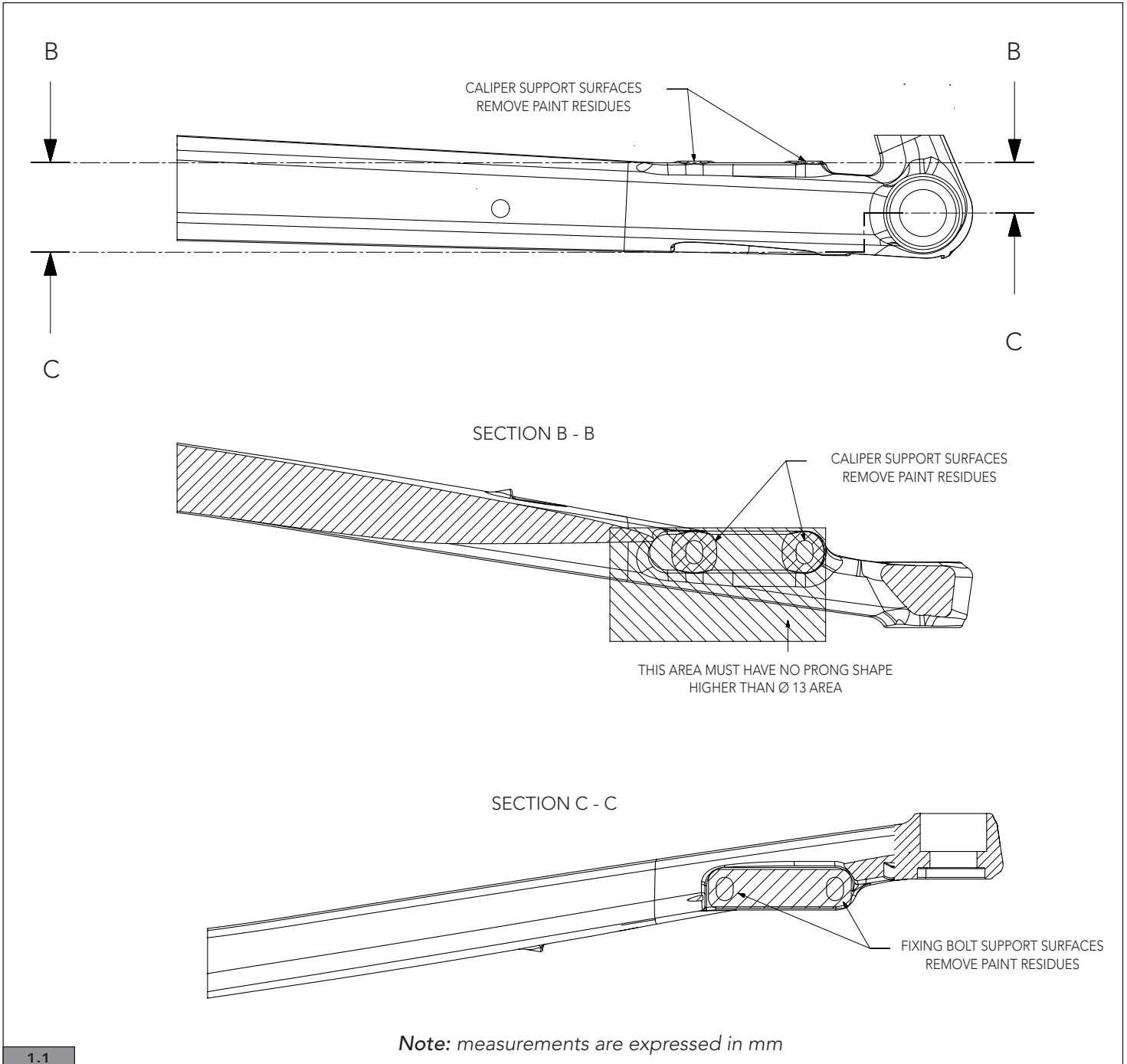

1.1

- Using the frame cutter tool make sure the calliper contact surface on the fork and the left-hand chain stay are perpendicular to the discs, grinding the chain stay if necessary in order to achieve this (Fig.2).

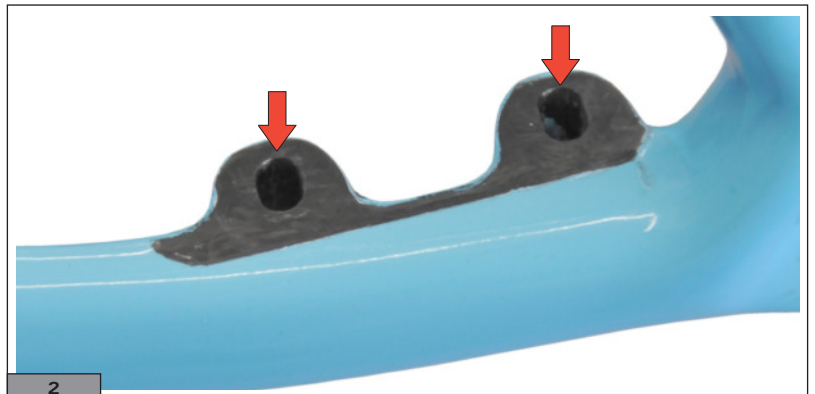

2

5.3 - INSTALLING THE ERGOPOWER COMMANDS

IMPORTANT

Always check the tables in the technical manual that provide information on product compatibility with previous Campagnolo product ranges.



Please remember that all the assembly, disassembly, adjustment and maintenance procedures are described in the technical manual, which is available on our website www.campagnolo.com. Scan this QR CODE to access the first page directly.

- For instructions on how to install the cables and sheaths for the operation of the rear derailleur and the Ergopower Ultra Shift and Power Shift front derailleur, please refer to the "Ergopower commands" chapter of the technical manual, which is available on our website www.campagnolo.com.
- For instructions on how to install the Ergopower EPS and connect them to the EPS V3 interface, please refer to the "Assembly of the EPS groupset" chapter of the technical manual, which is available on our website www.campagnolo.com.

5.4 - MOUNTING THE DISC ONTO THE WHEEL

WARNING!

Only original discs, pads and oil that are supplied with the Campagnolo drivetrain or original replacement parts must be used; failure to respect the above requirements could result in accidents, physical injuries or even death.

1) Position the disc on the hub so that the knurled surface is visible (Fig.1).

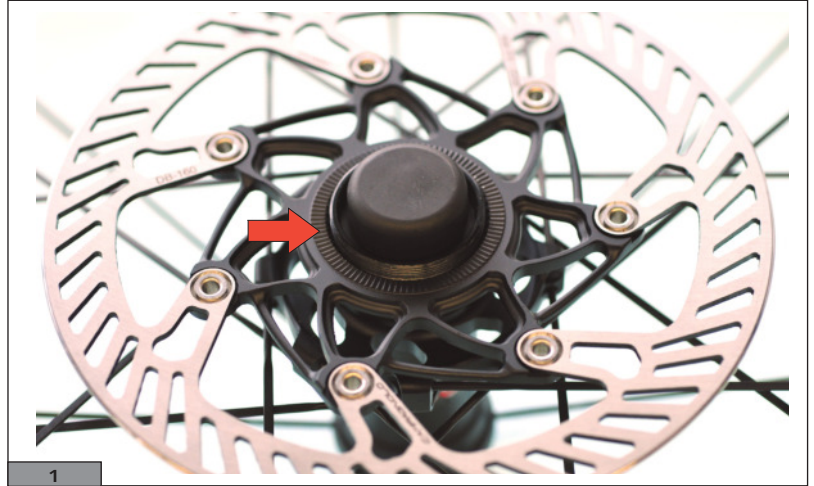

2) Insert the washer and locknut to hold the disk in place (Fig.2).

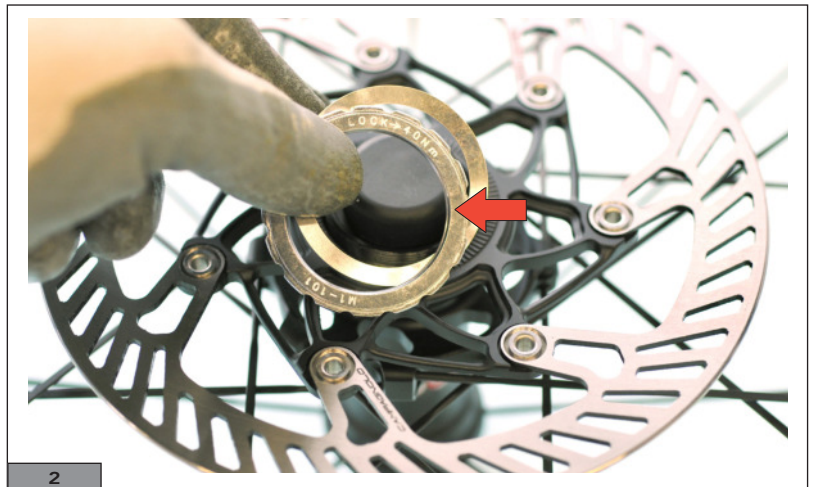

3) Screw on the locknut (Fig.3).

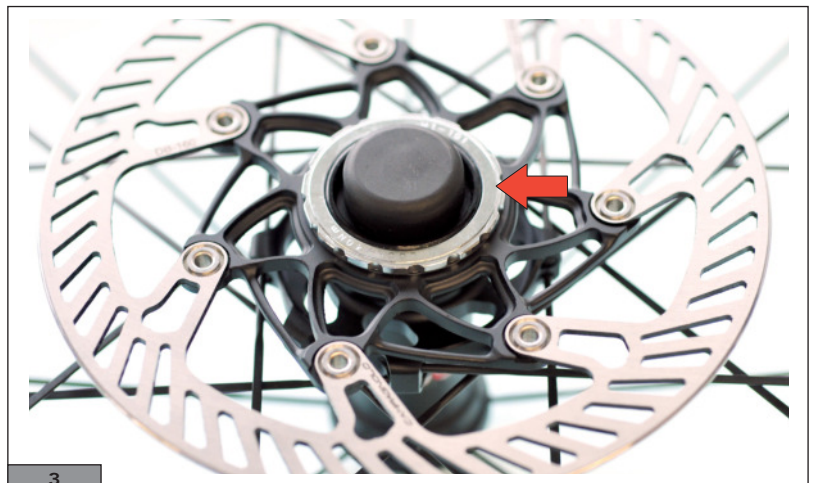

3) Tighten the locknut (Fig. 4).

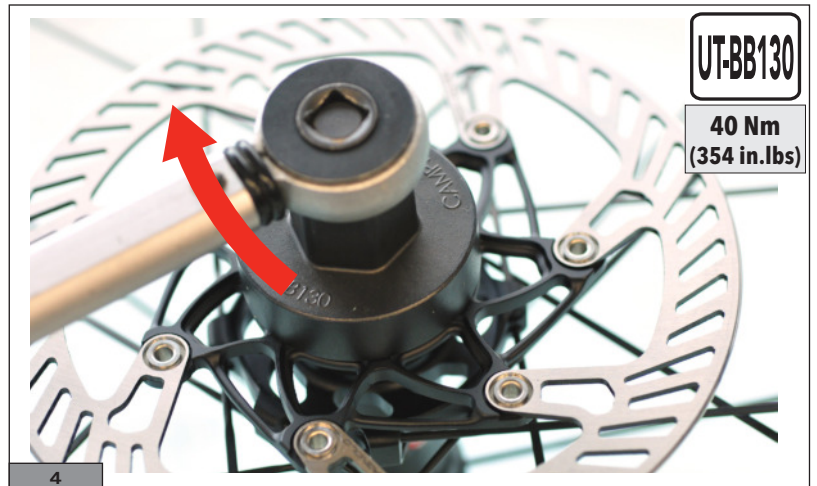

5.5 - INSTALLING THE FRONT DISC BRAKE HYDRAULIC SYSTEM

If the wheel has been mounted onto the bicycle, remove it beforehand in order to prevent soiling of the disc due to potential oil leaks from the system during the mounting and bleeding phase. If the disc becomes soiled you then have to clean and degrease it.

1) Identify the front and rear callipers on the basis of their geometry and distance from the screw holes on the frame (70 mm) (Fig.1 - Fig.2).

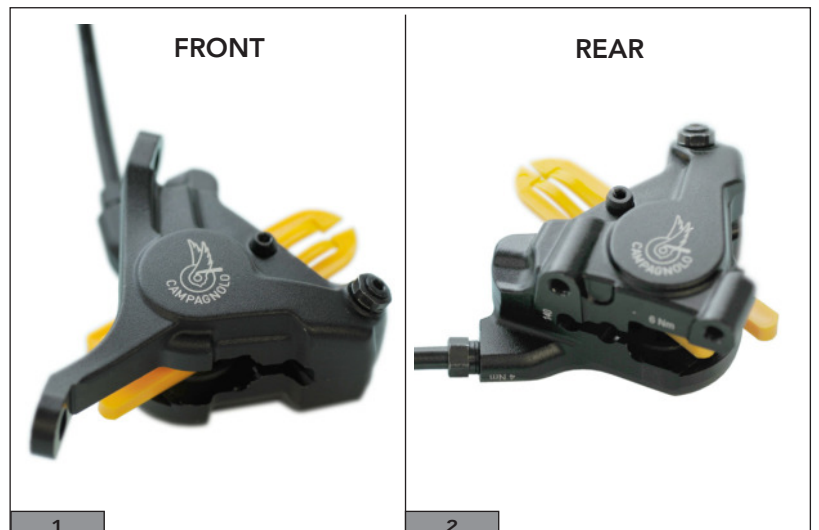

2) Remove the transportation block, the securing pin and the pad fastener screw (Fig.3).



3) Fit the oil level tool (which has a width of 10.5 mm). If necessary, push the pistons back into the calliper using the transportation block (Fig.4).

4) Fix the tool in place by screwing the pad fastener screw back on (Fig.5).

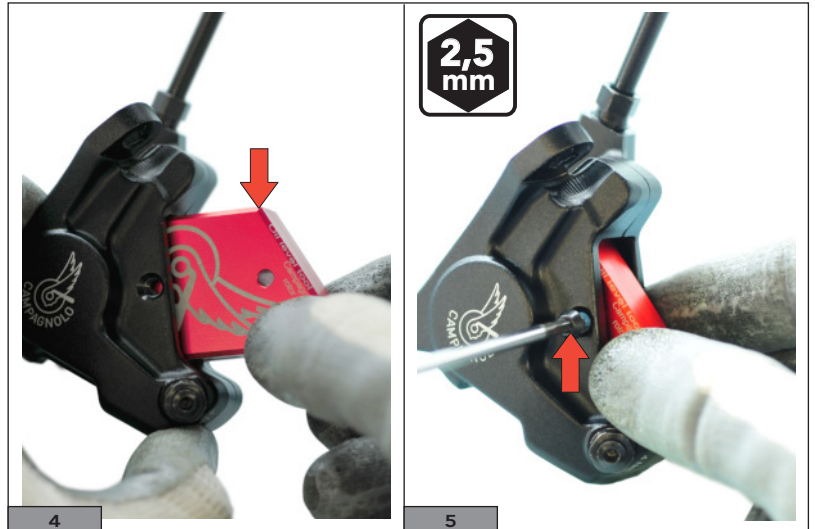

5) The length of hose must now be removed from the calliper: loosen the nut, remove the nut and then the hose (Fig.6).

6) Temporarily install the calliper onto the fork with two screws supplied (Fig.7).

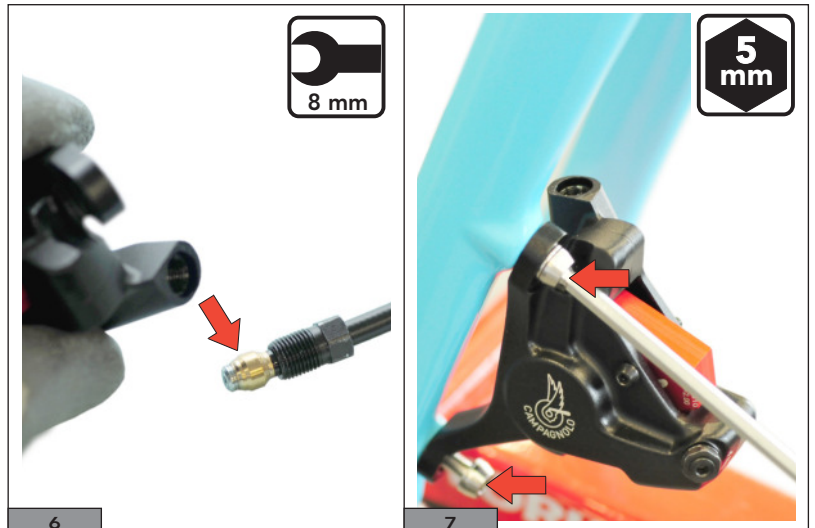

7) Once the command has been installed on the handlebar, insert the hydraulic hose into the hole present on the left chain stay of the fork (Fig.8).

The barb driver on the end of the hose can be used to guide the hose via a rear derailleur hose mounted onto it (Fig.8). Insert the cable into the top hole and once it has been threaded through the bottom hole pull on it so that the hose can slide through the lower area of the fork.

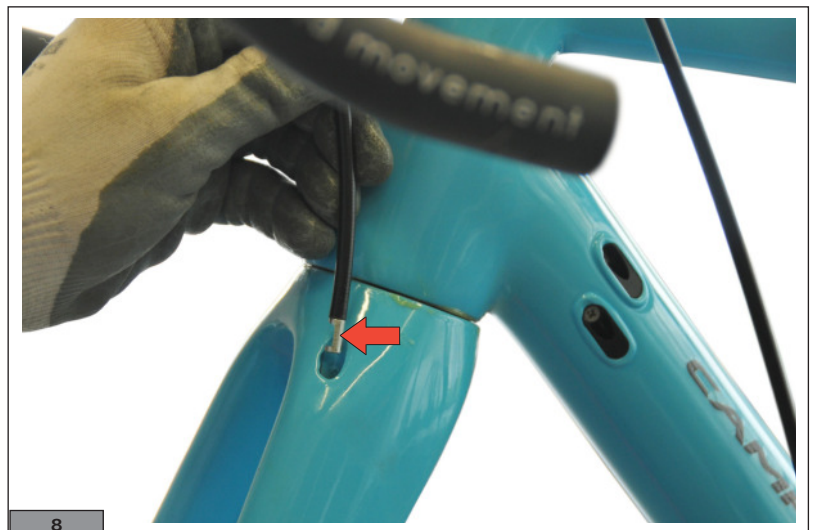

8) Assess the correct length of the hose by observing its position in the handlebar area and bearing in mind that the part entering the calliper should measure 11 mm in length from the cut end of the hose (Fig. 9). Once the barb (with the head measuring 4 mm in length) has been inserted, the part of the hose and barb entering the calliper should measure approximately 15 mm.

We recommend that the length is greater than what is required in case subsequent operations (11 and/or 14) are not completed successfully.

9) Use the cutter, making sure that the cut is at a 90° angle to the hose (Fig. 10).

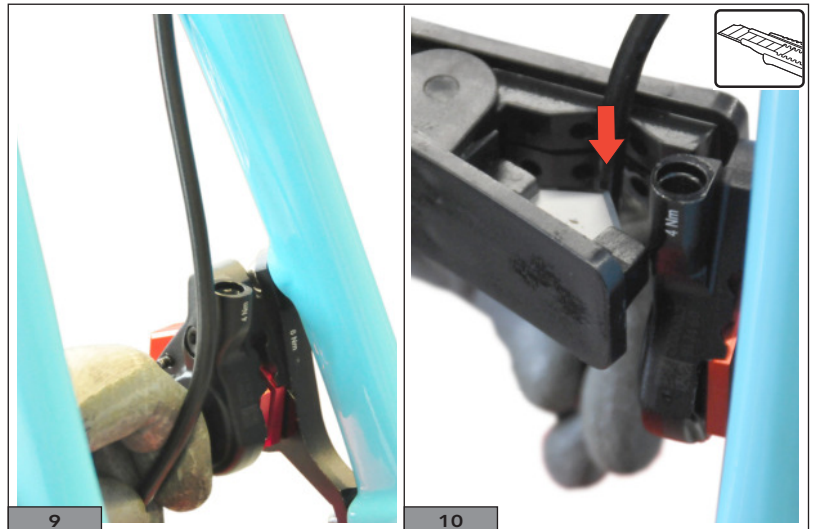

10) Insert part of the barb into the hose and push it in using the driver tool (Fig. 11).

11) Check that the end of the hose touches the barb and that the olive can be inserted on the hose (Fig.12). If it is not possible, check to see whether the length of barb inserted is excessive, causing the hose to bulge out.

This situation - which would cause the incorrect positioning of the olive - is solved by returning to step **8** in the procedure, cutting the end of the hose and refitting the barb.

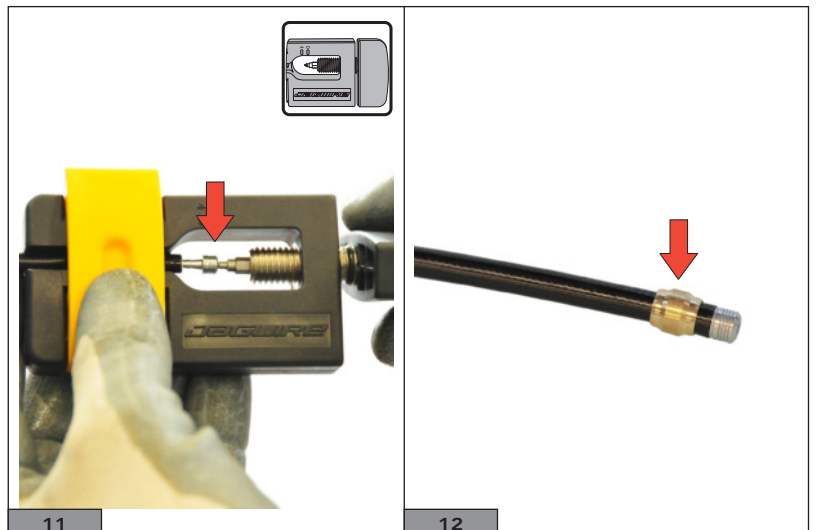

12) Insert the olive into the calliper (Fig. 13).

13) Hand-tighten the nut on the calliper so as to screw it on safely and with precision without the constraint of the hose (Fig. 14).

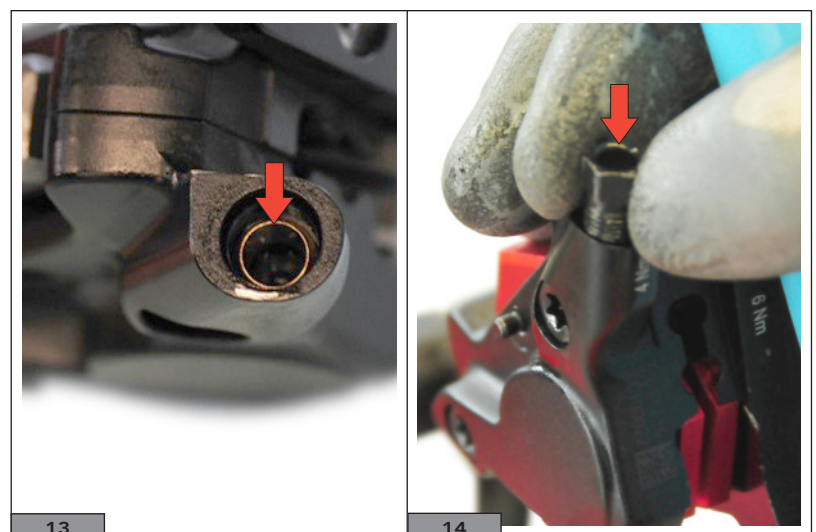

14) Insert the hose into the calliper and tighten the nut ensuring that the hose is properly inserted into the calliper (Fig. 15).

15) Once it has been sufficiently tightened, unscrew the nut in order to extract the hose and check that the chamfering on the olive allows the barb to protrude from the olive itself (Fig.16). If this is not the case, you must return to step 8 and cut the end of the hose, otherwise the seal between the hose and barb would not be effective.

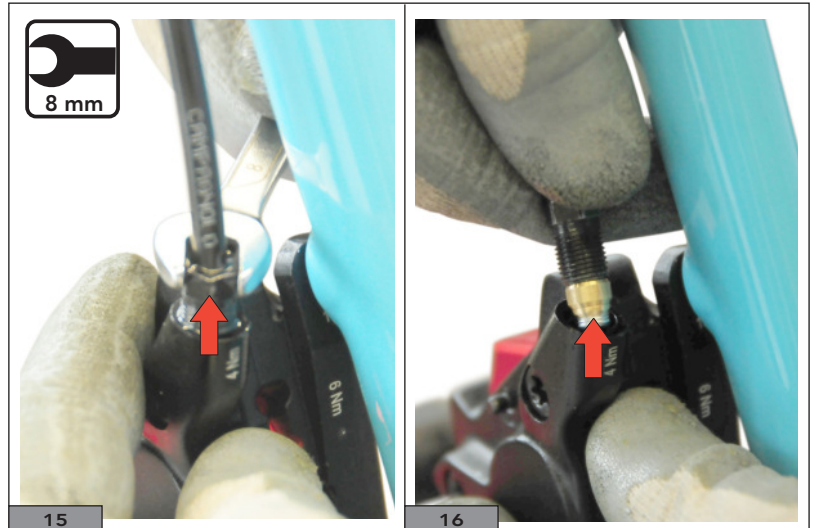

16) Insert the hose into the calliper once again, screw on and tighten the nut again to the prescribed torque, taking care not to damage the hose with the tool (Fig. 17).

17) Now proceed with bleeding the hydraulic system.



5.6 - INSTALLING THE REAR DISC BRAKE HYDRAULIC SYSTEM

- If the hydraulic hose passes through the bottom bracket shell and no other separate routing is required, the axle cover cylinder needs to be installed in the bottom bracket (supplied with hydraulic component set - Fig.1).
- If the wheel has been mounted onto the bicycle, remove it, in order to prevent potential oil leaks from the system during the mounting and bleeding phase from soiling the disc (which you would then have to clean and degrease).

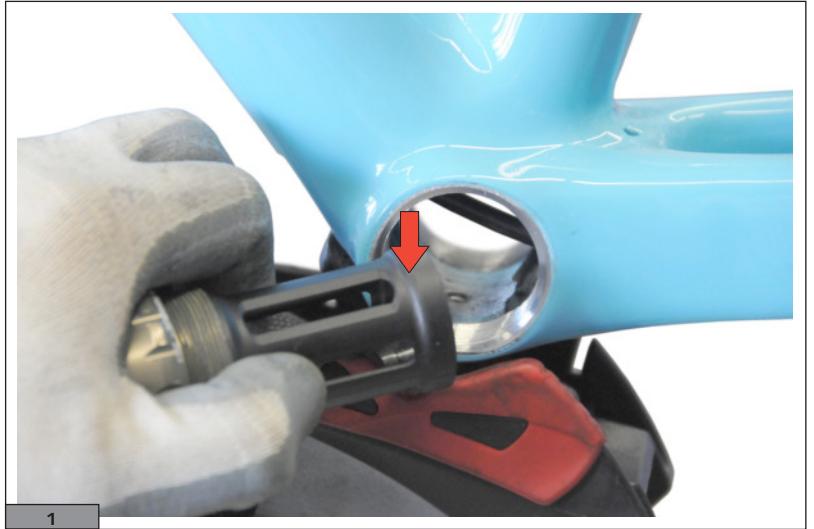

WARNING!

Take care to ensure that no lubricants, oils, solvents or waxes for polishing the frame are deposited on the brake pads or discs. If this occurs, the braking power will be reduced or lost completely. In these circumstances, the bike must not be used. Do not attempt to clean the pads, but instead simply replace these, and clean the discs with a degreasing agent. Failure to observe the above instructions could cause accidents, physical injury or even death.

- 1) Identify the front and rear callipers on the basis of their geometry and distance from the fixing holes on the frame (34 mm) (Fig. 2/ Fig. 2.1).

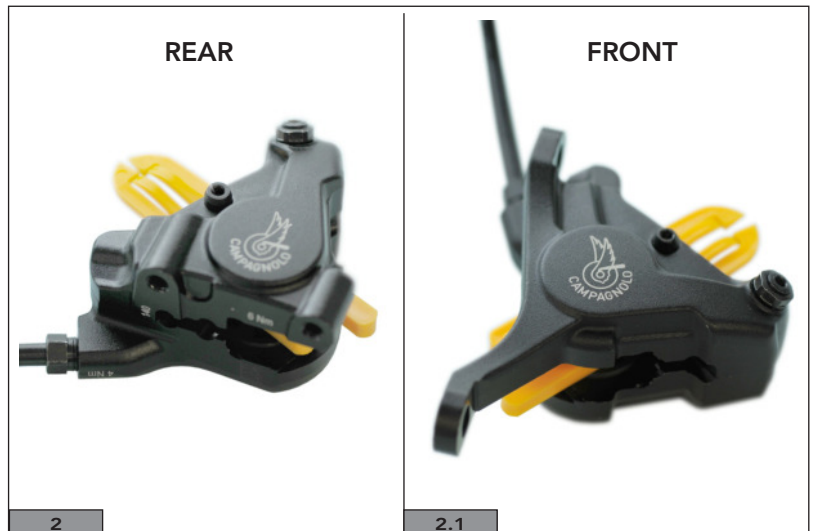

- 2) Remove the transportation block, the securing pin and the pad fastener screw (Fig.3).



3) Fit the oil level tool (which has a width of 10.5 mm). If necessary, push the pistons back into the calliper using the transportation block (Fig.4).

4) Fix the tool in place by screwing the pad fastener screw back on (Fig.5).

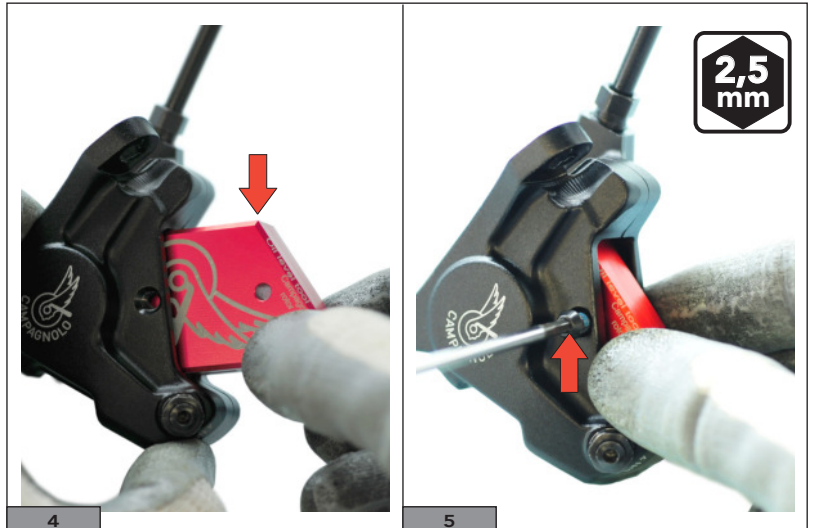

5) The length of hose must now be removed from the calliper: loosen the nut, remove the nut and then the hose (Fig.6).

6) Once the command has been installed on the handlebar, insert the hydraulic hose into the hole present on the left chain stay of the fork (Fig.7).

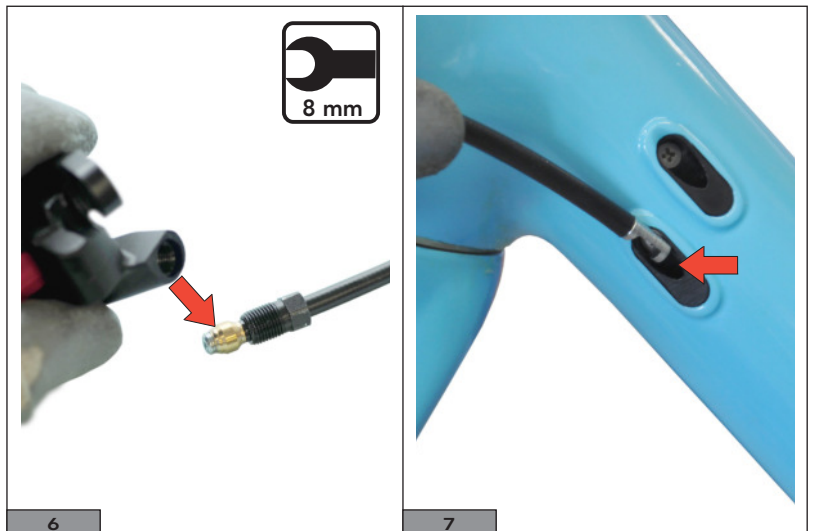

The barb driver on the end of the hose can be used to guide the hose via a rear derailleur hose mounted onto it (Fig.).

Insert the cable into the hole on the frame (Fig. 8) and once it has been threaded through the chain stay pull on it so that the hose runs through the frame (Fig. 9).



7) Assess the correct length of the hose by observing its position in the handlebar area and bearing in mind that the part entering the calliper should measure 11 mm in length from the cut end of the hose (Fig. 10). Once the barb (with the head measuring 4 mm in length) has been inserted, the part of the hose and barb entering the calliper should measure approximately 15 mm.

We recommend that the length is greater than what is required in case subsequent operations (10 and/or 13) are not completed successfully.

8) Use the cutter, making sure that the cut is at a 90° angle to the hose (Fig. 11).

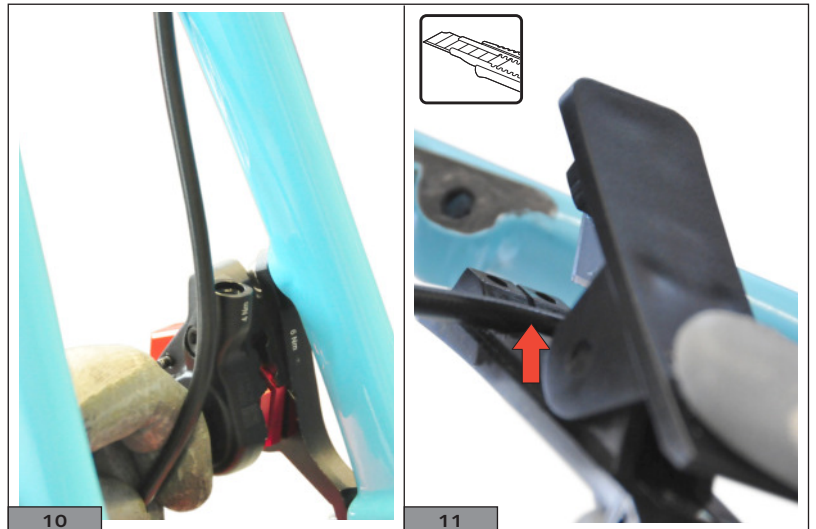

9) Insert part of the barb into the hose and push it in using the driver tool (Fig. 12).

10) Check that the end of the hose touches the barb and that the olive can be inserted on the hose (Fig.13). If it is not possible, check to see whether the length of barb inserted is excessive, causing the hose to bulge out.

This situation - which would cause the incorrect positioning of the olive - is solved by returning to step 7 in the procedure, cutting the end of the hose and refitting the barb.

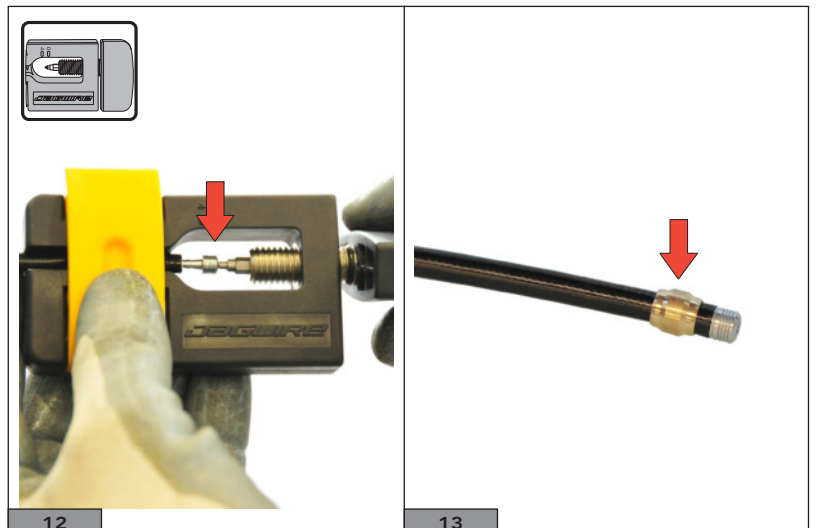

11) Holding the rear calliper, insert the olive into the calliper and hand-tighten the nut on the calliper so as to screw it on safely and accurately, without the constraint of the hose (Fig. 14).

12) Insert the hose into the calliper and tighten the nut ensuring that the hose is properly inserted into the calliper (Fig. 15).



13) Once it has been sufficiently tightened, unscrew the nut in order to extract the hose and check that the chamfering on the olive allows the barb to protrude from the olive itself (Fig.16). If this is not the case, you must return to step 7 and cut the end of the hose, otherwise the seal between the hose and barb would not be effective.

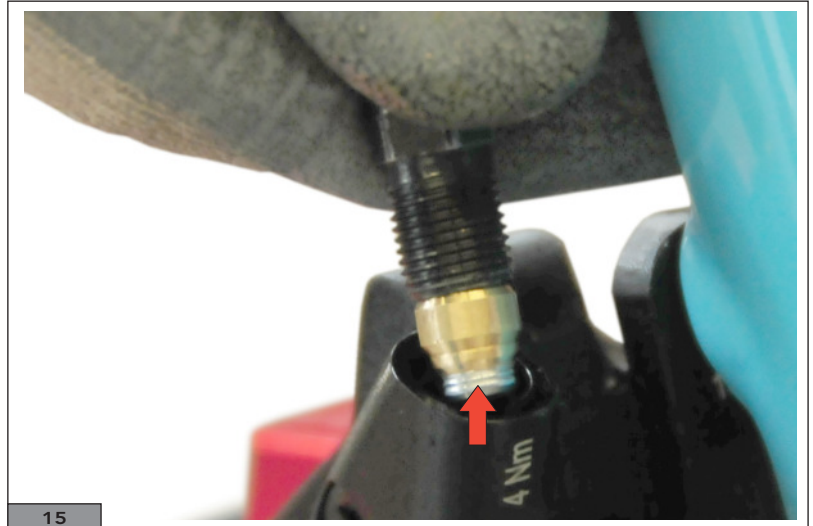

16) Insert the hose into the calliper once again, screw on and tighten the nut again to the prescribed torque, taking care not to damage the hose with the tool (Fig. 17).

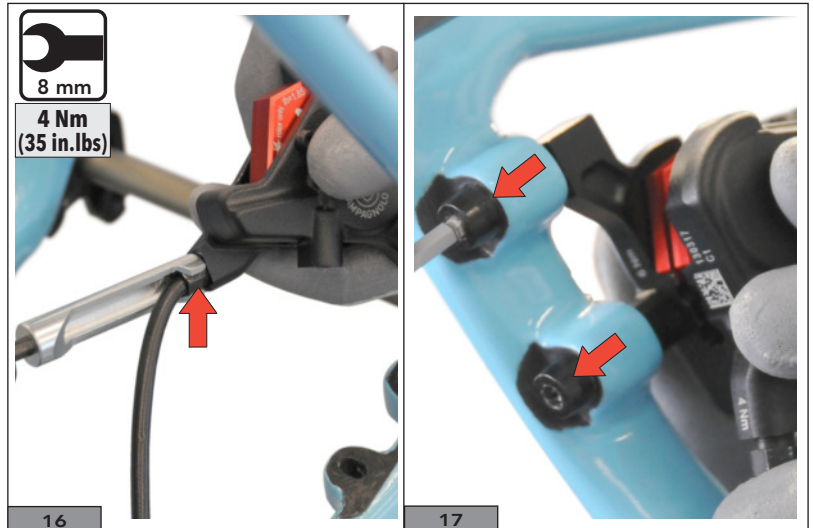

17) Temporarily install the calliper onto the left-hand chain stay fitting the two Campagnolo screws following the indications in the table on the right, which ensures that the screws are inserted at least 5 mm into the calliper.

18) Now proceed with bleeding the hydraulic system.

HEIGHT OF SCREW SEAT ON FRAME (mm)	L SCREW (mm)
10-14	19
15-19	24
20-24	29
25-29	34
30-34	39
35	44

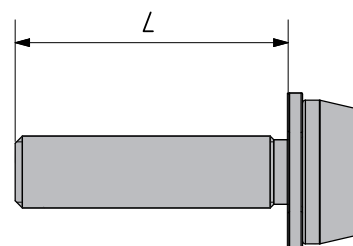

5.7 - BLEEDING THE FRONT/REAR DISC BRAKE HYDRAULIC SYSTEM

Introduction: The images illustrating this procedure relate to the installation of the left-side command and the front calliper but they are also relevant for the installation of the right-hand command and the rear calliper.

1) The new command features adjustable free stroke (AMS) set to the short position (S). This means that less oil is used to fill the system if the long position (L) is set. Always check that the idle stroke is set to the S position before bleeding (Fig. 1).

2) Remove screw from the bleed valve (Fig.2).

3) Fill the syringe without a hole and with the longer hose (M4 thread) around $\frac{3}{4}$ its capacity with Campagnolo mineral oil (code LB-200 / LB-200S / LB-200B) and screw the syringe onto the bleed valve (Fig.3).

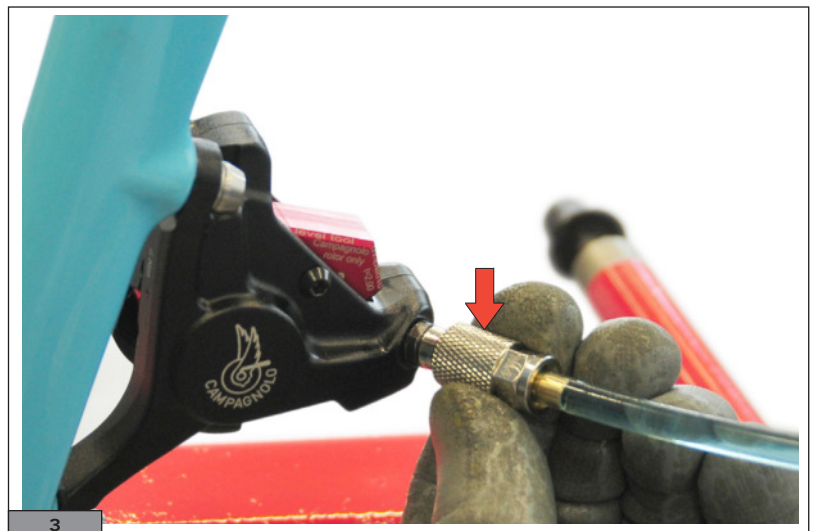

! DANGER!

Use Campagnolo LB-200 / LB-200S / LB-200B mineral oil only.

Using DOT oil or any other type other than Campagnolo oil, could damage the rubber seals irreparably. Failure to observe the above instructions could cause accidents, physical injury or even death.

4) The valve is currently closed: open the valve by turning the nut on the valve itself anticlockwise by approximately $\frac{1}{4}$ turn (Fig.4 - Fig. 5).

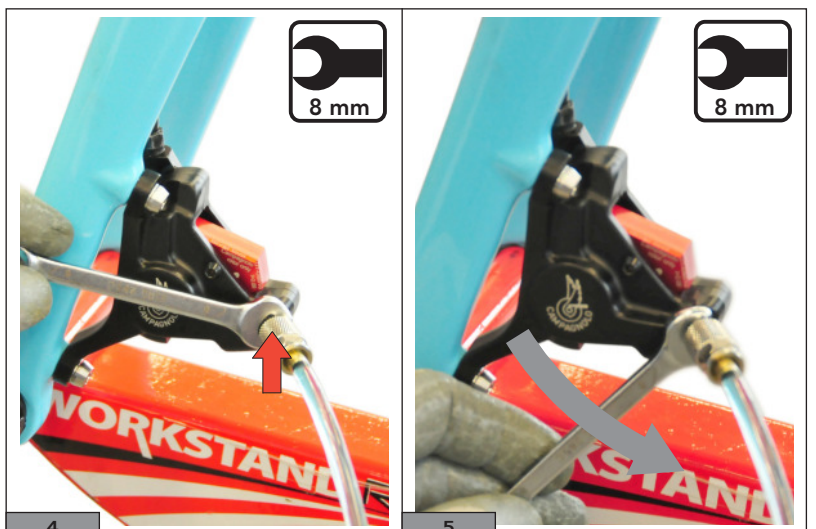

! WARNING!

Do not turn the valve by more than half a turn to prevent damage to the O-ring inside.

5) Lift the command cover and remove the bleed screws on the command (Fig. 6).

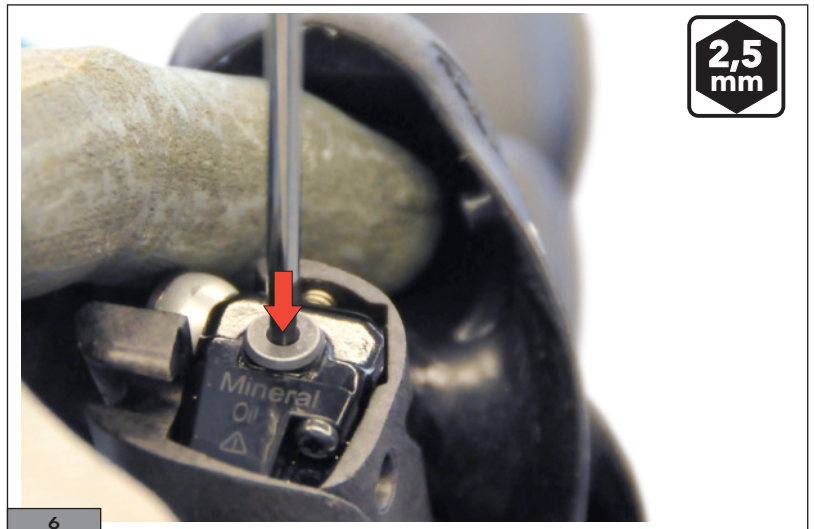

6) Screw on the empty syringe with the short hose (M6 thread) (Fig. 7) so that the piston is positioned above the lateral hole (Fig.8).

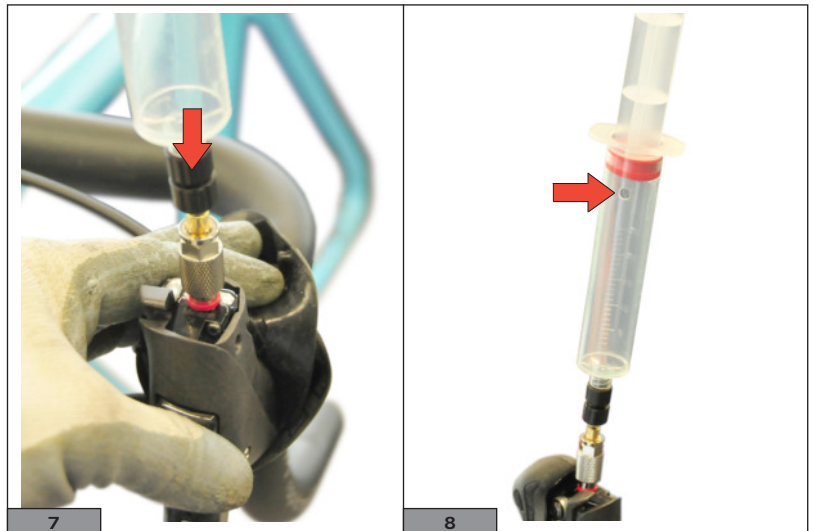

7) Push the plunger of the syringe connected to the calliper (Fig. 9) to expel all the air trapped in the system until the oil exiting from the command bleed valve has filled the syringe by at least 50 %. Ensure that the bottom syringe is not left without oil, so as to prevent air from entering the calliper.

If the system is not new, aspirate the oil already in the system, remove the syringe, plug the hole on the syringe and dispose of the used oil in accordance with local/regional/national legislation. Then reconnect the syringe and refill with new oil.

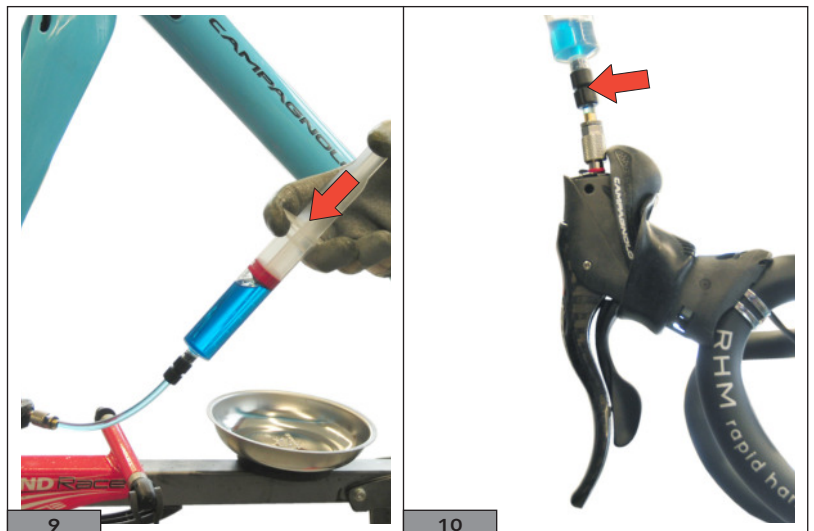

8) Slowly aspirate oil with the syringe connected to the calliper, watching for air bubbles, until the syringe is at least 50% full. Ensure that the top syringe is not left without oil, so as to prevent air from entering the calliper.(Fig.10).

Repeat this pushing and aspiration procedure until the oil contains no more air (2 or 3 times approx.).

9) While pressing down on the syringe plunger, pull the brake lever and release without accompanying, in order to eliminate any trapped air in the command area (in the master cylinder) (Fig.11).

10) While aspirating with the syringe, pull the brake lever several times as if you were braking to expel any remaining air in the calliper (Fig.12).



11) When all air has been expelled, ensure that the level of oil in the syringe is above 1 cm approx. and close the bleed valve by turning the key clockwise (Fig.13).

12) Remove the syringe from the command, ensuring there is no oil leakage by sealing the lateral hole on the bleed syringe with one finger (Fig.14).



13) Check that there is oil in the screw seat and tighten the bleed screw (Fig.15).

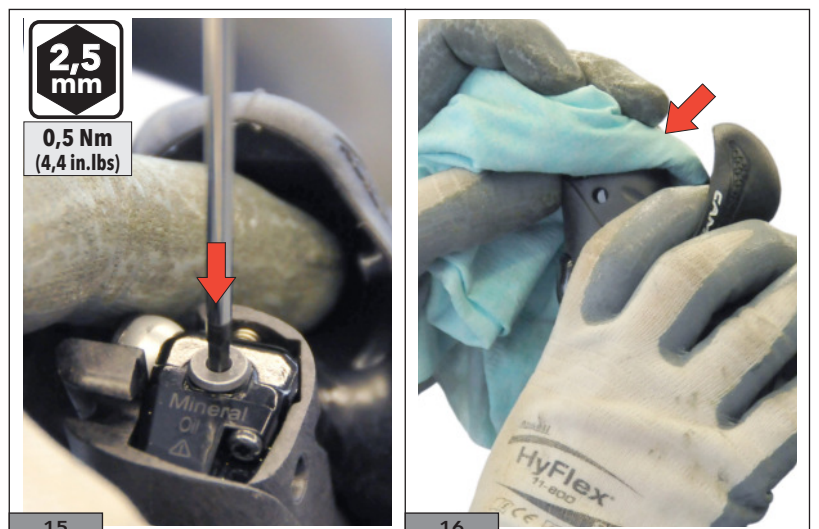

! WARNING!

Do not exceed the specified tightening torque, as this may damage the hydraulic system.

14) Using alcohol, clean away any oil present in the upper command area (Fig.16).

15) Remove the oil between the valve and the syringe connection, aspiring with the syringe to prevent any remaining oil underneath the valve screw from leaking once this is in place in its seat (Fig.17).



16) Remove the syringe from the calliper (Fig.18).

17) Fit the bleed valve screw (Fig.19).



18) Torque tighten the bleed valve (Fig. 20).

19) Using alcohol, clean away any oil from the calliper (Fig. 21).



20) Refit the wheel and align the calliper with the disc, with the centring tool still in the calliper: this is to provisionally align the calliper with the disc (Fig. 22).

21) Unscrew the pad pivot that holds the oil level tool in place and remove the oil level tool (Fig.23).

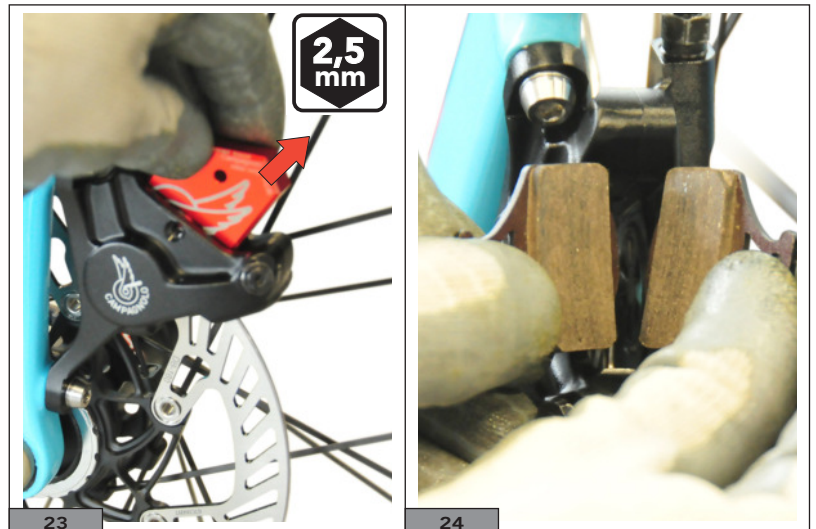

22) Position the pads so that the metal support is in contact with the pistons (Fig. 24).

23) Mount and tighten the pad pivot (Fig. 25).

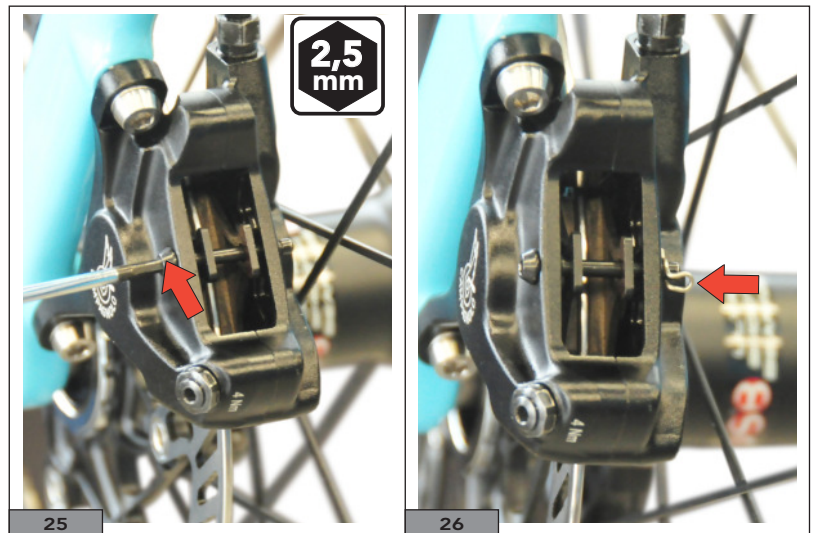

24) Position the securing pin on the pivot (Fig. 26).

25) Align the calliper with the disc keeping the brake lever pressed and tighten the two calliper screws (Fig. 27).



5.8 - INSTALLING REAR CALLIPER SPACER 140 MM FOR USE WITH DISC D.160 mm

Mount the rear spacer on the calliper for a 140 mm disc observing the direction indicated on the spacer itself. (Fig.1).
Tighten the screws included with the spacer, to a torque of **6 Nm (53 in.lbs)**.

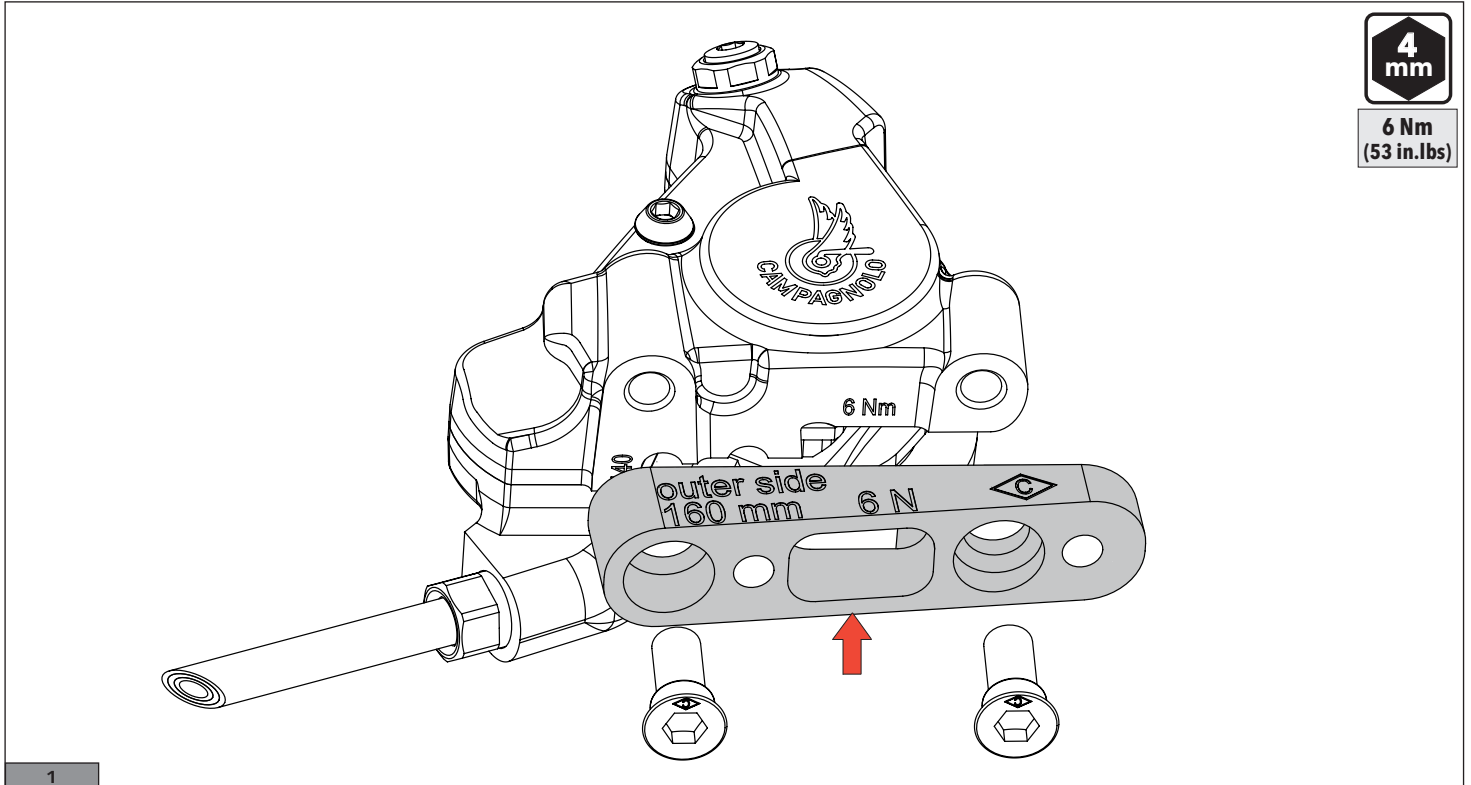

6 - EXTRAORDINARY MAINTENANCE

6.1 - TOOLS FOR EXTRAORDINARY MAINTENANCE PROCEDURES (in addition to those involved in mounting and bleeding the hydraulic system)

- Standard workshop tools.
- N°2 - T10 Torx wrench.

6.2 - REPLACING THE LEFT-HAND BRAKE LEVER

WARNING!

Faults or malfunctions in the brake system could lead to a sudden increase in the brake lever stroke, which could result in poor braking performance and cause accidents, personal injury or even death.

6.2.1 - DISASSEMBLY

- 1) Hold the axle in place from the inside (Fig.1).
- 2) Remove the axle screw from the outer side (Fig.2).

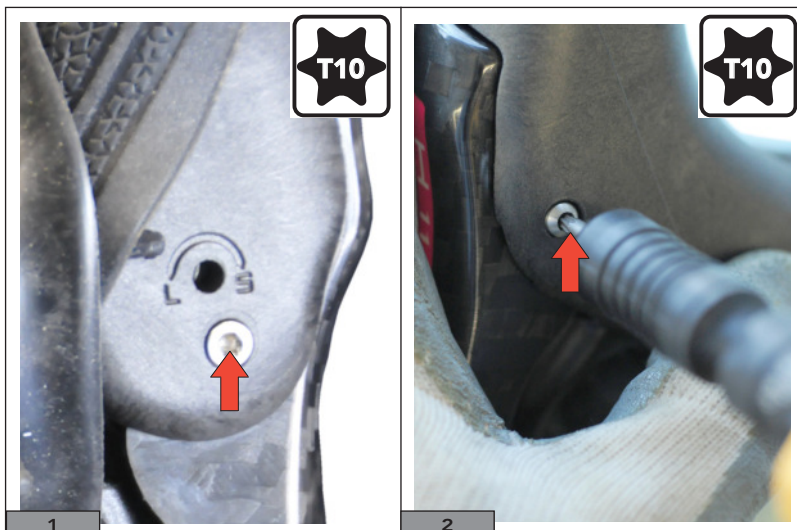

- 3) Remove the brake level (Fig. 3).



6.2.2 - ASSEMBLY

1) Identify the left-hand brake lever thanks to its upper geometry and the presence of a deep groove near the hole on the inner side (Fig.4).

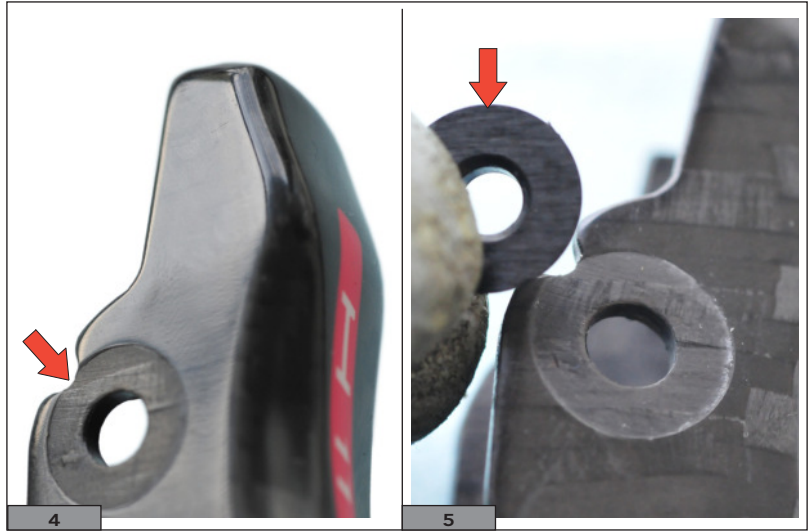

2) Install the smooth bush (i.e. with no teeth) on the inner surface of the lever (Fig.5).

3) Install the bush with teeth on the outer surface of the lever (Fig. 6).

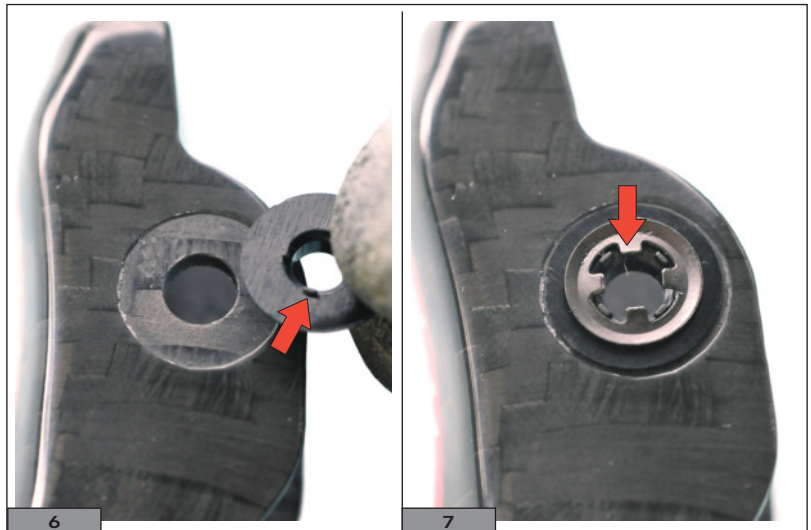

4) Install the check ring on the outer bush so that the teeth are positioned to act as a check when the pivot is inserted (Fig. 7).

We recommend applying a small amount of grease to the check ring, to prevent it from falling during assembly.

5) Fit the spring in the hole on the command body (Fig. 8).

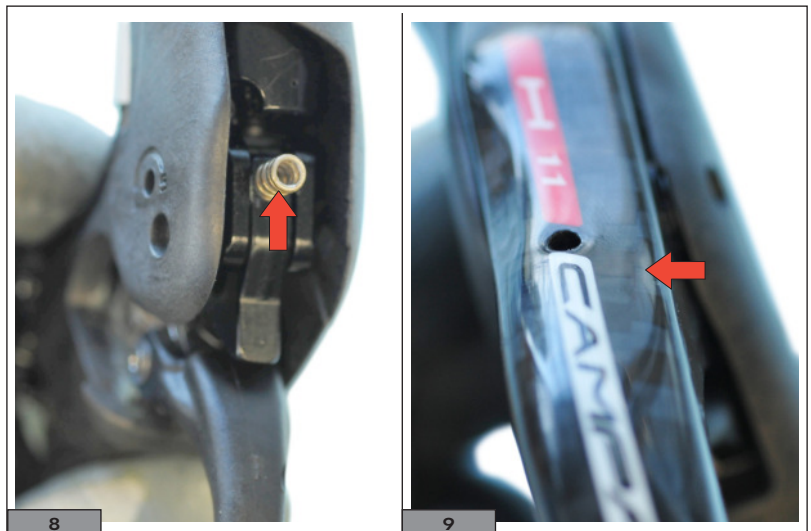

We recommend applying a small amount of grease to the spring, to prevent it from falling during assembly.

6) Insert the lever in the command body (Fig. 9).

7) Hold the bushes and ring in position while you insert a screwdriver from the outer side of the command (Fig. 10).

8) Insert the pivot from the inner side, drawing back the screwdriver at the same time (Fig. 11).

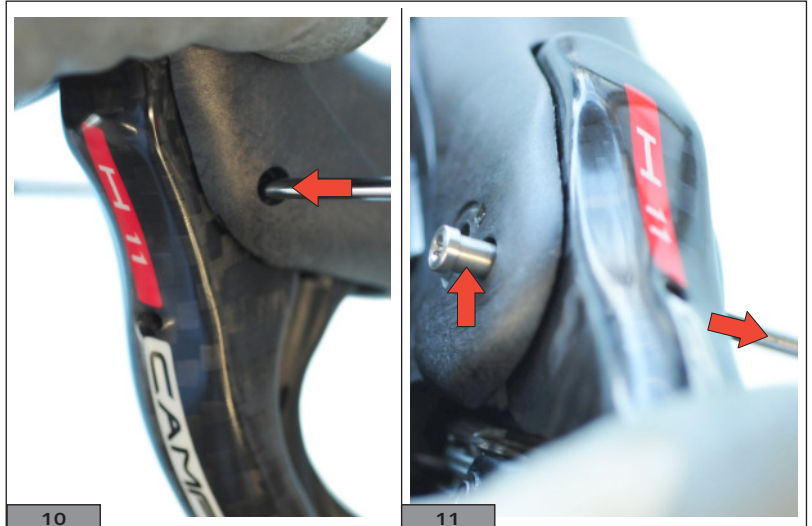

9) Hold the axle in place from the inside (Fig. 12).

10) Screw on the pivot screw (Fig. 13).

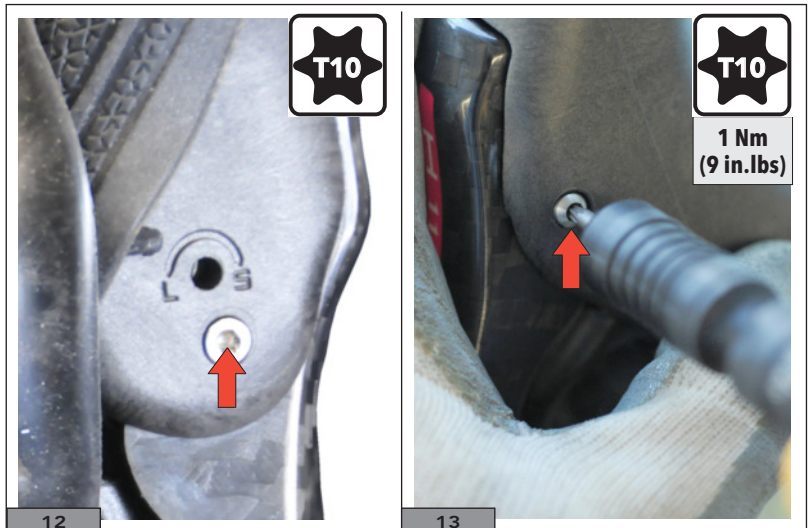

6.3 - REPLACING THE RIGHT-HAND BRAKE LEVER

For instructions on how to assemble, disassemble and replace the right-hand brake lever, please refer to the procedure described in paragraph "6.2 REPLACING THE LEFT-HAND BRAKE LEVER", as the images contained within have the sole purpose of explaining extraordinary maintenance operations.

! WARNING!

Faults or malfunctions in the brake system could lead to a sudden increase in the brake lever stroke, which could result in poor braking performance and cause accidents, personal injury or even death.

6.4 - REPLACING THE HYDRAULIC HOSE

6.4.1 - DISASSEMBLY

1) Remove the screw from the valve present on the calliper (Fig. 1).

2) Install the long-tubed syringe (M4 connection) on the calliper (Fig. 2).

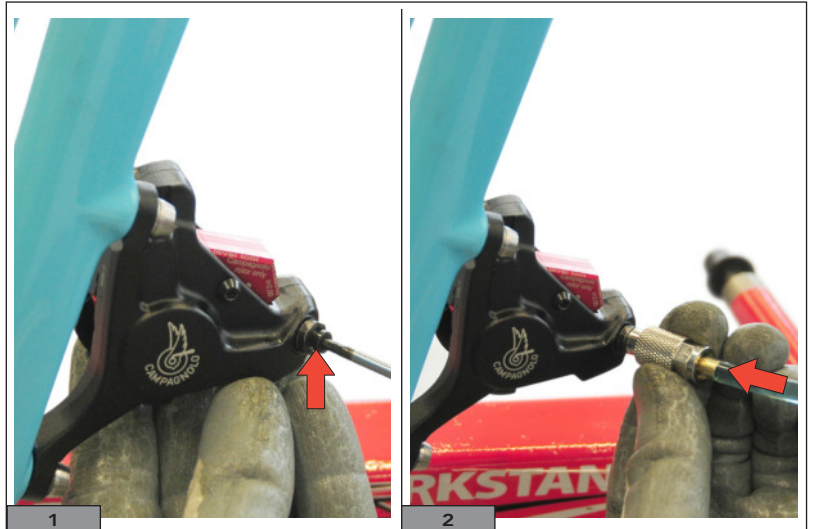

3) Open the valve by turning the nut on the valve itself anticlockwise by approximately 1/4 turn (Fig.3 - Fig. 4).

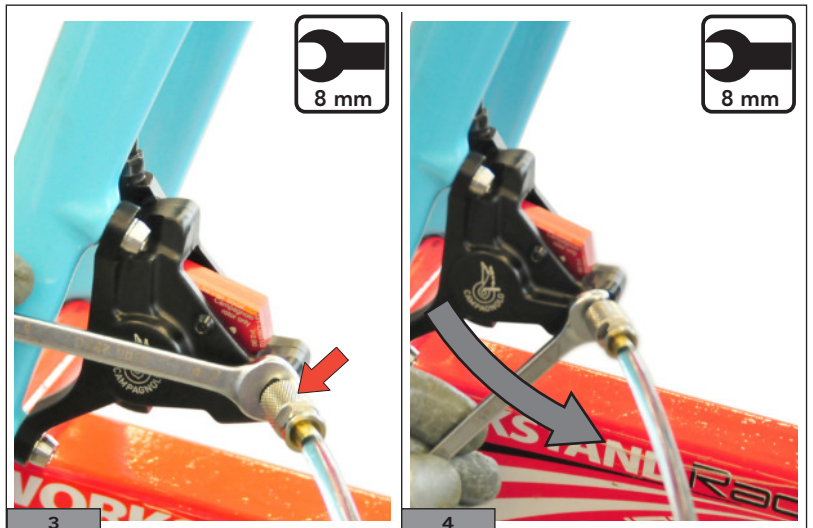

4) Lift the command cover and remove the bleed screws on the command (Fig. 5).

5) Drain the oil from the hydraulic system (Fig. 6).

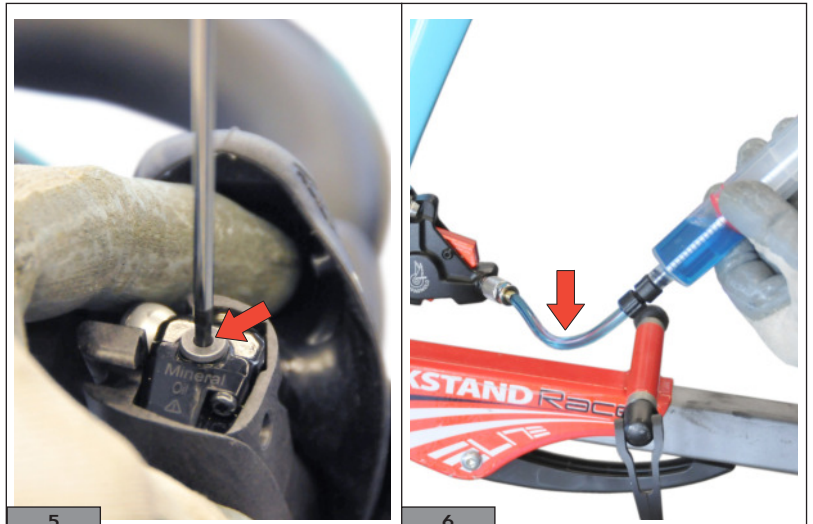

6) Loosen the nut on the calliper and remove the hose from the calliper (Fig. 7).

7) Lift the command cover to reveal the hose. In the case of commands for mechanical units, identify the plate that holds the hydraulic hose in position and loosen its screw (Fig. 8).

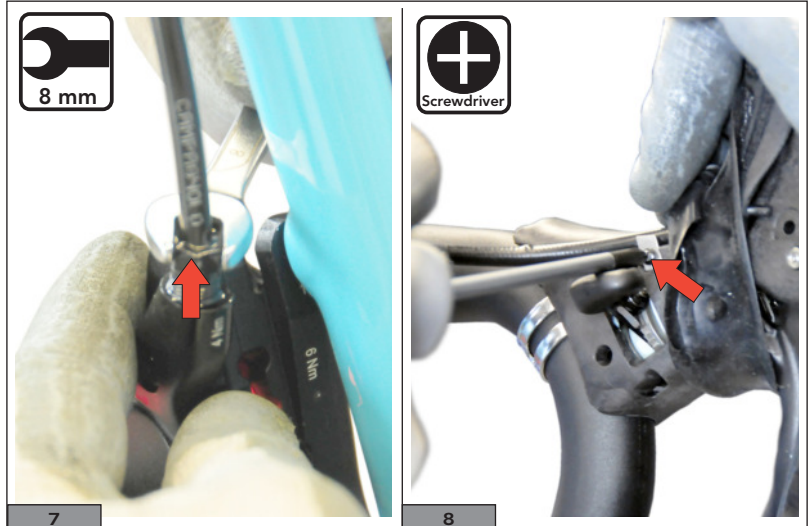

8) Remove the hose from the groove on the command body (Fig. 9).

9) Loosen the screw that connects the hose with the banjo to the master cylinder (Fig. 10).

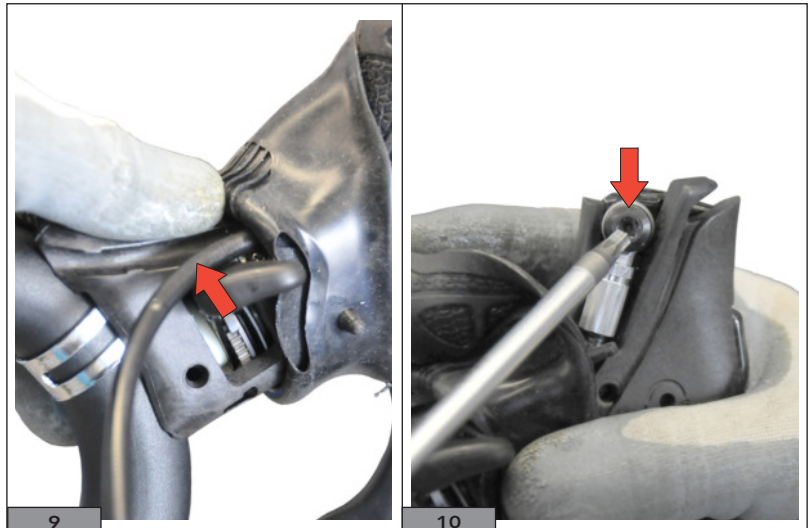

10) Remove the hydraulic hose from beneath the command cover (Fig. 11).

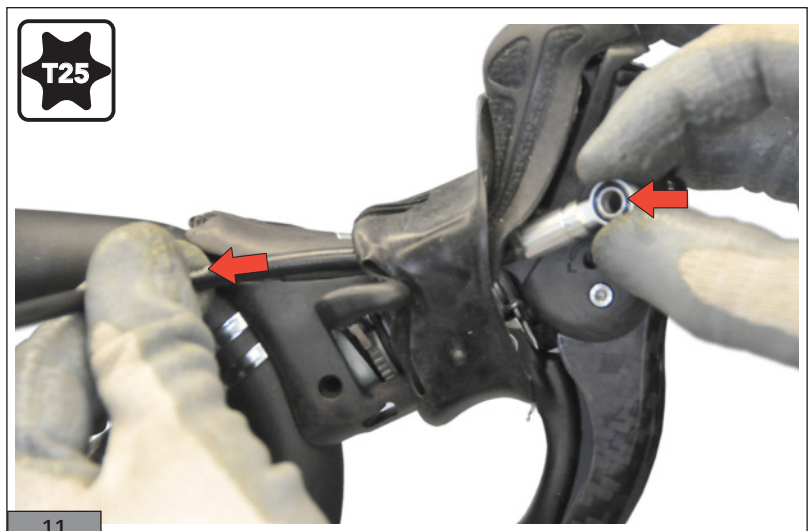

6.4.2 - ASSEMBLY

11) Let the hydraulic hose slide beneath the command cover to reach the front or rear calliper (Fig. 12).

12) Tighten the screw that connects the hose with the banjo to the master cylinder, checking that the two O-rings are present on the inner and outer sides of the banjo (Fig. 13).

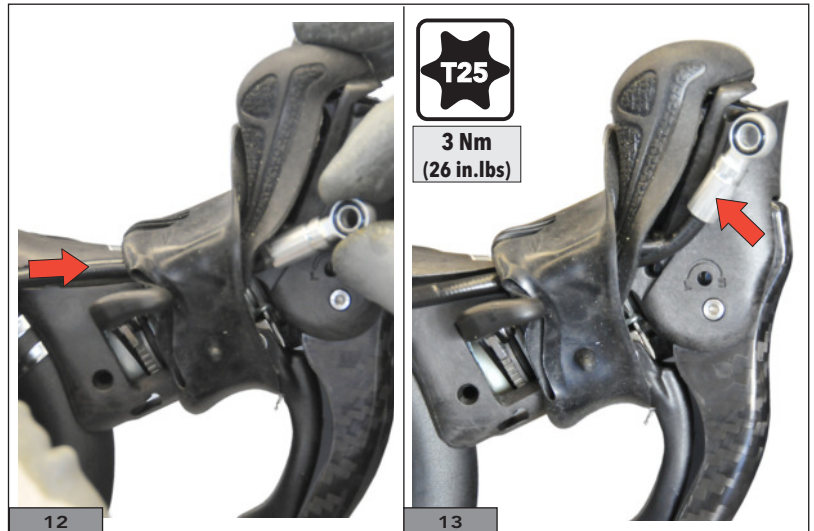

13) Position the hydraulic hose in the groove provided on the command (Fig. 14).

14) In the case of commands for mechanical units, identify the plate that holds the hydraulic hose in position and tighten its screw (Fig. 15).

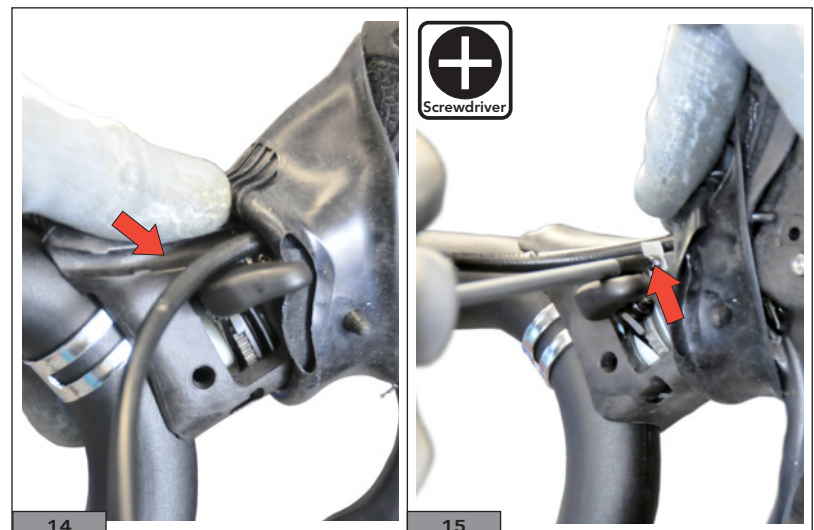

6.5 - REPLACING THE HYDRAULIC SYSTEM (MASTER CYLINDER AND HOSE)

Should you need to replace the hydraulic system for the command body, please follow the procedure on the next page carefully.

WARNING!

Faults or malfunctions in the brake system could lead to a sudden increase in the brake lever stroke, which could result in poor braking performance and cause accidents, personal injury or even death.

6.5.1 - DISASSEMBLY

Disassemble the brake lever as described in chapter "6.2 - REPLACING THE LEFT-HAND BRAKE LEVER/ DISASSEMBLY" or "6.3 - REPLACING THE RIGHT-HAND BRAKE LEVER".

15) Lift or remove the command cover. In the case of commands for mechanical units, identify the plate that holds the hydraulic hose in position and loosen its screw (Fig. 1).

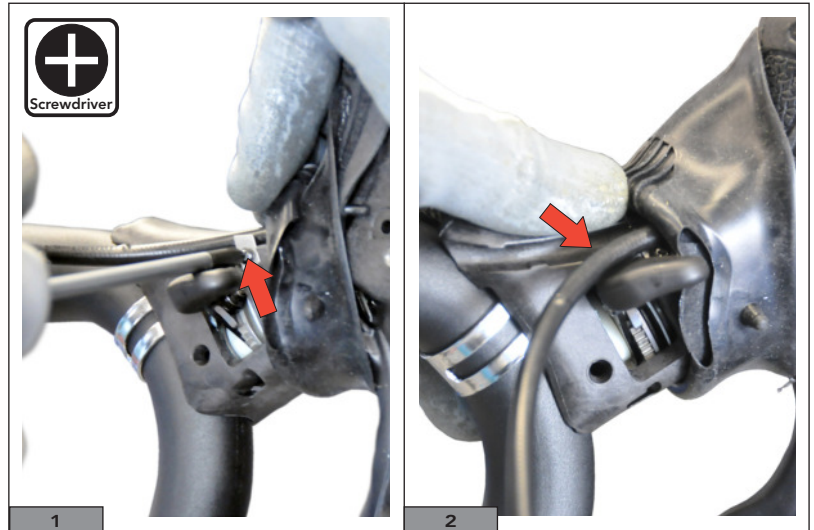

16) Remove the hose from the groove on the command body (Fig. 2).

17) Push in the area shown in Figure 3 to remove the master cylinder from the body; at the same time, keep your finger on the rear spring to avoid losing it (Fig. 4).

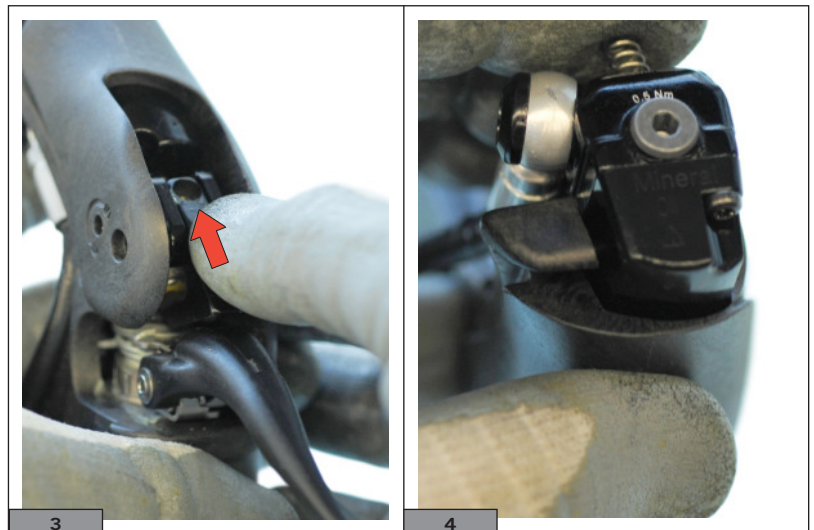

18) Loosen the nut on the calliper and remove the hose from the calliper (Fig. 5).



If there is still oil in the system and you wish to prevent it from leaking or if you wish to reuse the oil in the system, follow the procedure described in chapter "6.4 - REPLACING THE HYDRAULIC HOSE", up to and including point 5.

6.5.2 - ASSEMBLY

19) Insert the hydraulic component in the command body with the spring installed on the rear side (Fig. 6).

20) Press simultaneously on the master cylinder and the spring, making sure the spring is correctly positioned (Fig. 7).



21) Insert the tube in the groove present on the command body (Fig. 8). In the case of commands for mechanical units, identify the plate that holds the hydraulic hose in position and tighten its screw (Fig. 9).

22) Assemble the brake lever as described in chapter "6.2 - REPLACING THE LEFT-HAND BRAKE LEVER/ASSEMBLY" or "6.3 - REPLACING THE RIGHT-HAND LEVER/ASSEMBLY".

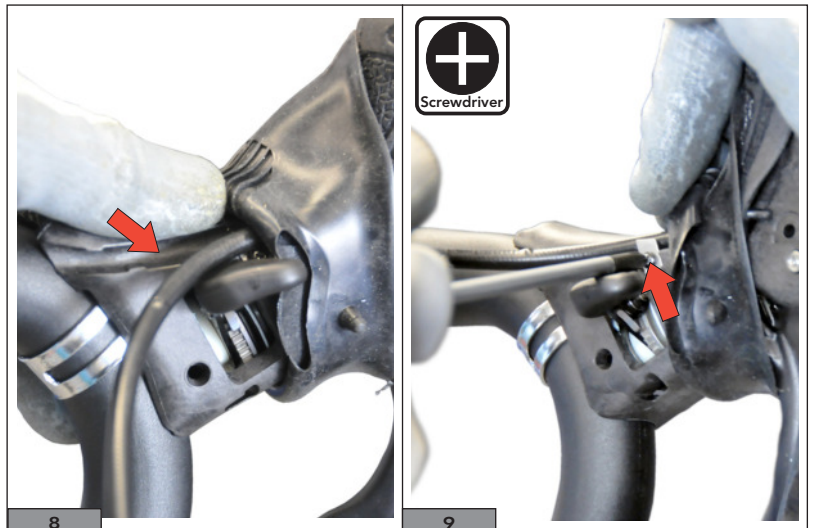

6.6 - REPLACING THE MASTER CYLINDER

Should you need to replace the master cylinder, we recommend you follow the procedure described in chapter "6.5 - REPLACING THE HYDRAULIC SYSTEM (MASTER CYLINDER AND HOSE)/DISASSEMBLY".

1) Loosen the screw that connects the hose with the banjo to the master cylinder (Fig.1).

2) If necessary, remove also the lockscrew from the opposite side of the hose and fit it on the other side of the master cylinder (Fig. 2).

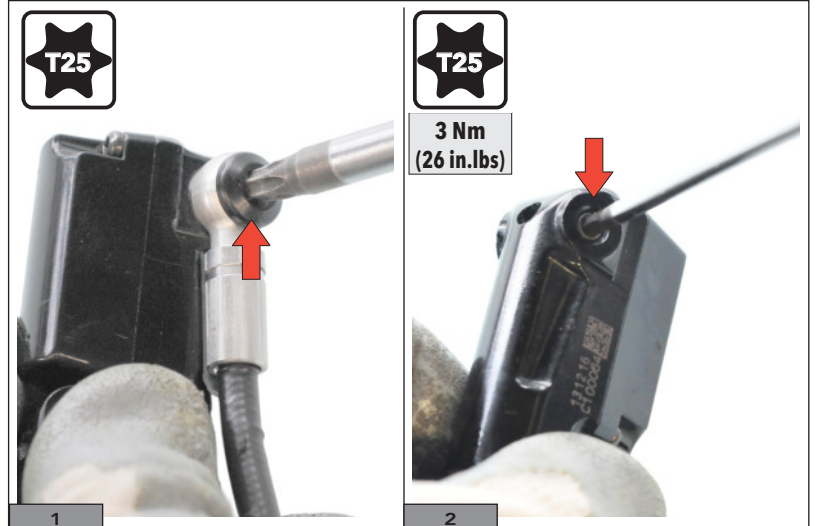

3) Check that the two O-rings are present on the two sides of the banjo and intact (Fig. 3).

4) Refit the screws to hold the hose with the banjo in place (Fig. 4).

Follow the procedure described in chapter "5.4 - REPLACING THE HYDRAULIC SYSTEM (MASTER CYLINDER AND HOSE)/ASSEMBLY".



7 - ORDINARY MAINTENANCE



WARNING!

Always wear protective gloves and glasses while working on the bicycle.

Campagnolo S.r.l. recommends that you check your bicycle at least once a year to ensure that the braking system along with all other parts of the bike are functioning correctly. However, depending on how the bicycle is used, more frequent inspections may be necessary.

7.1 - PERIODIC INSPECTION

Before each use and after a fall or collision, check that the bicycle components do not exhibit any of the following problems:

- Ergopower commands that are loose or not correctly positioned on the handlebar (Fig. 1).
- Ergopower commands, cables and sheaths that are damaged and no longer operating the front derailleur, rear derailleur and brakes correctly.
- Command levers that are jammed and do not return to the original position, or levers that are damaged.
- Command covers that are broken or damaged, which could cause the hands to slip.
- Cuts or damage to the brake system tubing
- Broken or damaged brake pads
- Excessive wear of the brake pads, where the wear indicator on one or more of the pads is no longer visible (Fig. 2).
- Incorrect position of the screw holding the pads in position and/or missing securing pin at the end of the screw (Fig. 3/Fig. 4).
- **discs with excessive wear: thickness of disc measured at a distance of 4 mm from the outer edge (Fig. 5) must not be less than 1.65 mm.**

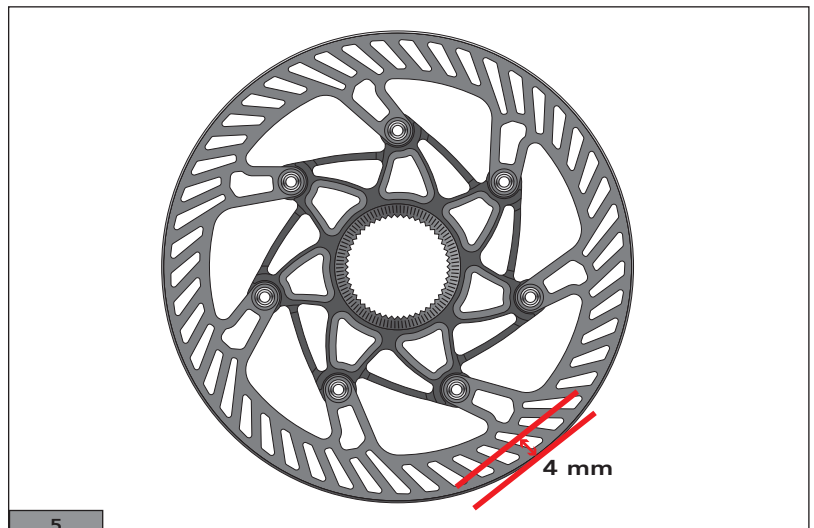
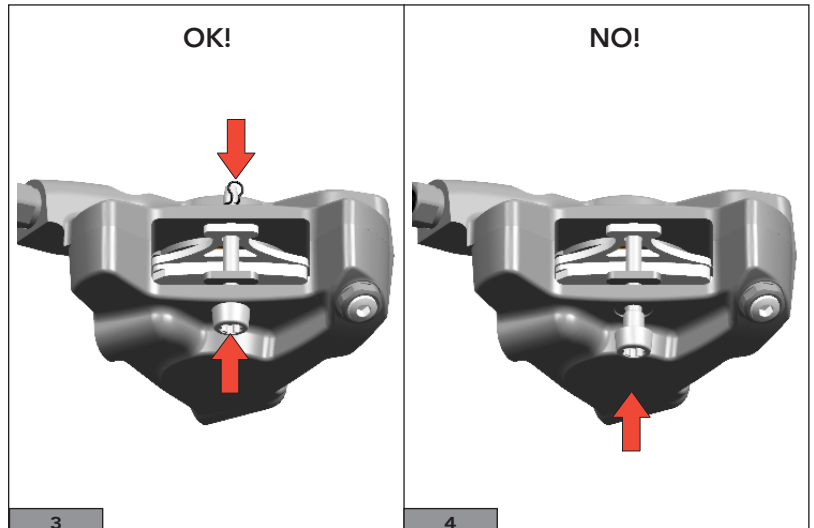
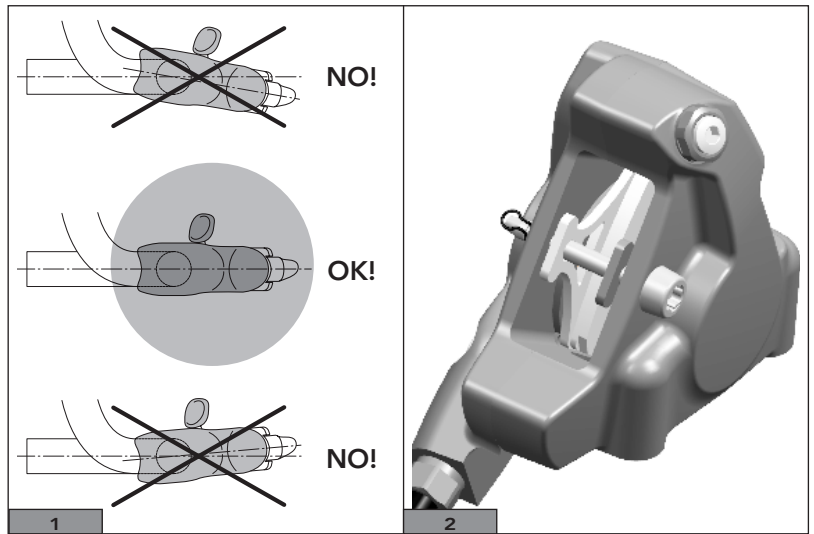

WARNING!

If when using the brakes you notice an unusual noise, check the wear and the position of the pads - these could be excessively worn, or fitted incorrectly, thus reducing braking performance.

CAUTION

Using a different brand of break pads instead of original Campagnolo® break pads, automatically voids the product warranty.

7.2 - LUBRICATION AND CLEANING

The duration of the components is variable based on the conditions of use, frequency and quality of maintenance. To ensure the components are well maintained, these must be cleaned frequently, especially in more extreme usage conditions (e.g. after every time the bicycle is washed, or ridden on wet, dusty or muddy roads, etc.).

WARNING!

Take care to ensure that no lubricants, oils, solvents or waxes for polishing the frame are deposited on the brake pads or discs. If this occurs, the braking power will be reduced or lost completely. In these circumstances, the bike must not be used. Do not attempt to clean the pads, but instead simply replace these, and clean the discs with a degreasing agent. Failure to observe the above instructions could cause accidents, physical injury or even death.

- Make sure the pads are not embedded with any debris (stones, broken glass, etc.); if this is the case, remove this.

WARNING!

Do not use products to reduce the noise when braking - these products also reduce the braking power, and as such, can lead to accidents, physical injury or even death.

- Use cleaning products that are compatible with braking systems which use mineral oil. Do not use cleaning products for systems which use DOT oil, as these can damage the rubber seals irreparably.
- Never wash your bicycle using pressurised water. Pressurised water - even from a normal garden hose - may infiltrate through the seals and into your Campagnolo®, components, causing irreparable damage to them. Wash your bicycle and the Campagnolo® components by delicately cleaning with water and neutral soap.
- Check that any holes present in the bottom bracket shell are not obstructed and let water drain from the frame.

WARNING!

Saline conditions (such as roads in winter and in coastal areas) may cause galvanic corrosion in the majority of the exposed components of the bicycle. To prevent damage, malfunctions and the consequent risk of accident, carefully rinse, clean and dry all components that are subject to corrosion.

7.2.1 - PROCEDURE FOR CLEANING AND LUBRICATING ERGOPOWER COMMANDS

The gear command and front derailleur sheaths are pre-lubricated and need no additional lubrication.

7.3 - TRANSPORTATION

- If you need to remove the wheels from the bike, ensure that you have inserted the transport tool (Fig. 1/Fig. 2) which prevents the brake pads from coming together if the brake lever is accidentally engaged, making it impossible to insert the disc. If this occurs, proper conditions must be restored immediately.
- The braking system can be transported by air; no adjustments need to be made. **Make sure that the brake system tubing is protected and cannot become bent.**

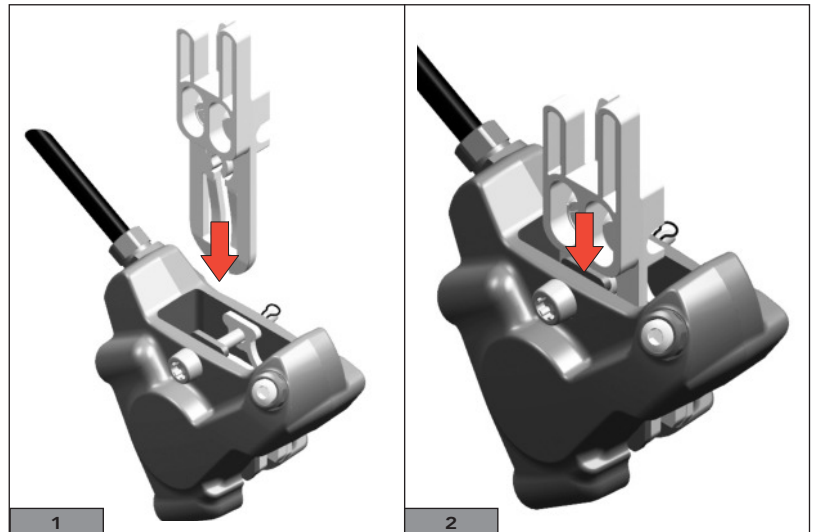

- After transportation:
 - Check that there are no oil leaks.
 - Check that no component of the bicycle is damaged, particularly the cables and hoses that form part of the braking system.
 - Engage the brake lever 4-5 times in a safe place to ensure that the front and rear brake systems are working properly.
- Do not expose the product to temperatures below -10 ° C (5 ° F) or above 60 ° C (131 ° F). For this reason, do not leave these components in locked cars parked in the sun and do not store them near radiators or other heat sources. Do not store carbon or plastic products in direct sunlight.